



Residential
Fan Coil Unit

Carisma Whisper
CFF-ECM
CFF

TECHNICAL MANUAL



TABLE OF CONTENTS

Introduction	p. 4
--------------	------

Carisma Whisper CFF-ECM

Version and main components	p. 5
Versions	p. 6
Eurovent Certification	p. 7
Cooling emission	p. 8
Heating emission	p. 11
Water side pressure drop	p. 14
Operation limits	p. 15
Dimensions	p. 16
Valves	p. 18
Configurations and electronic controls	p. 20
Controls	p. 21

Carisma Whisper CFF

Version and main components	p. 27
Versions	p. 28
Eurovent Certification	p. 29
Cooling emission	p. 30
Heating emission	p. 33
Water side pressure drop	p. 36
Operation limits	p. 37
Dimensions	p. 38
Valves	p. 40
Controls	p. 42

Accessories

Accessories	p. 44
-------------	-------



Sabiana take part to the Eurovent program of fan coil performance certification. The official figures are published in the web site www.eurovent-certification.com. The tested performances are:

Total cooling emission at the following conditions:

- | | | |
|---------------------|--------------|---------------|
| • water temperature | +7 °C E.W.T. | +12 °C L.W.T. |
| • air temperature | +27 °C d.b. | +19 °C w.b. |

Heating emission (2 pipe units) at the following conditions:

- | | | |
|---------------------|----------------|---------------|
| • water temperature | +45 °C E.W.T. | +40 °C L.W.T. |
| • air temperature | +20 °C | |
| Static pressure | Fan absorption | |

Sensible cooling emission at the following conditions:

- | | | |
|---------------------|--------------|---------------|
| • water temperature | +7 °C E.W.T. | +12 °C L.W.T. |
| • air temperature | +27 °C d.b. | +19 °C w.b. |

Heating emission (4 pipe units) at the following conditions:

- | | | |
|--------------------------|---------------|---------------|
| • water temperature | +65 °C E.W.T. | +55 °C L.W.T. |
| • air temperature | +20 °C | |
| Water side pressure drop | Sound power | |

INTRODUCTION

The Carisma Whisper fan coil unit, available in the CFF-ECM version (with AC synchronous motor) and in the CFF version (with asynchronous motor), combines a reduced dimension with a modern aesthetic, while maintaining great performances in terms of sound and consumption.

The excellent values in terms of sound levels have been maintained in all working conditions, without any resonance phenomenon at any frequency.

Carisma Whisper includes the MV version for wall installation and the IV version for concealed installation; the MV version combines a reduced dimension, until 126 mm depth only, with a modern aesthetic that perfectly suits with any kind of furnishing.

Carisma Whisper CFF-ECM range with EC electronic motor

The CFF-ECM range makes use of the excellent experience gained with the fan coil units with inverter board, first in the world in production since 2009, and which have had great success on all markets.

The latest synchronous inverter driven BLAC brushless and sensorless electronic motor with permanent

magnets is controlled by an Inverter board designed and developed in Italy.

The electronic board is directly fitted on the motor.

The air flow can be varied continuously with a 1-10 V signal.

The continuous air flow control improves the acoustic comfort and allows a more punctual reply to the variation of the thermal loads and a greater stability of the requested ambient temperature.

The extreme efficiency, also at a low speed, makes possible a great reduction in electric consumption with absorption values, under normal operating conditions, that are no greater than 5 Watt.

Carisma Whisper CFF-ECM version with radiant panel

During the winter operation by selecting this operating mode on the CB-Touch control, the clever management of the radiant panel, of the fan and of the fan coil hot water valve is activated in order to reduce the ventilation always to the minimum necessary. Under any steady room condition, the fan is OFF and the fan coil heats only into the radiant mode. In this version, thanks to this operation, the CFF-ECM-MV-R-CB-T is particularly suitable for the night mode.



VERSION AND MAIN COMPONENTS

Range includes 5 air flow rates (from 75 to 645 m³/h) and 2 versions (standard with casing and for concealed installation), each one equipped with 2 row coil.

The standard versions with the casing are available in the following combinations:

- without control (CFF-ECM-MV)
- with CB-E control (CFF-ECM-MV-CB-E)
- with CB-Touch control (CFF-ECM-MV-CB-T)

The CB-E and CB-Touch versions are supplied with their power units (UP-ECO and UP-Touch) fitted on the unit.

The CB-E control must always be connected with a programmable thermostat (not supplied by us).

The CFF-ECM range is perfect to meet all air-conditioning requirements of residential and work environments like offices, shops, restaurants and hotel rooms.

Outer casing

Made of galvanized steel and with plastic outer casing. The air diffuser, that is placed over the top of the unit, is of adjustable type.

White RAL 9003.

Inner casing

Made of 1 mm galvanized steel, a rear panel and two lateral sides insulated with 3 mm polyolefin (PO) foam (B-s2-d0 EN 13501-1).

Filter

Polypropylene cellular fabric regenerating filter.

The filter frame, made of synthetic material, is inserted into special plastic sliding guides fastened to the internal structure for easy insertion and removal of the filter.

Fan assembly

Made of plastic tangential fan with anti-vibration fins.

The fan hub, dynamycally and statically balanced, is directly secured onto the motor shaft.

Electronic motor

Electronic motor with three phase permanent magnet brushless electronic motor that is controlled with reconstructed current according to a BLAC sinusoidal wave.

The inverter board that controls the motor operation is powered by 230 Volt, single-phase and, with a switching system, it generates a three-phase frequency modulated, wave form power supply.

The electric power supply required for the machine is therefore single-phase with voltage of 230 V and frequency of 50 - 60 Hz.

Coil

It is manufactured from drawn copper tube and the aluminium fins are mechanically bonded onto the tube by an expansion process.

The coil has two Ø 1/2 inch BSP internal connections.

The coil has Ø 1/8" inch BSP air vent and drain.

The coil is not suitable for use in corrosive atmosphere or in environments where aluminium may be subject to corrosion.

Flow and return pipe connections are situated at the same end on the left side looking at the unit. On request we can deliver the unit with the connections on the right end side: this must be specified on the order as this operation can not be carried out on site during installation.

Radiant panel (CFF-ECM-MV-R-CB-T version)

The casing front panel is equipped with electric heating panel at low energy consumption, that allows to heat the room successfully by reducing the fan operation, thanks to the irradiation contribution.

Valves

The versions without valves or with mounted valves are available for all sizes.

The available valves are:

- 2 way
- 3 way

The valves can be ordered separately and easily installed on the basic units without valves.

Condensate collection tray

Made of plastic (ABS UL94 HB) and fixed to the internal structure. The outside diameter of the condensate discharge pipe is Ø 15 mm.

VERSIONS

Standard version with casing - MV / MV-R

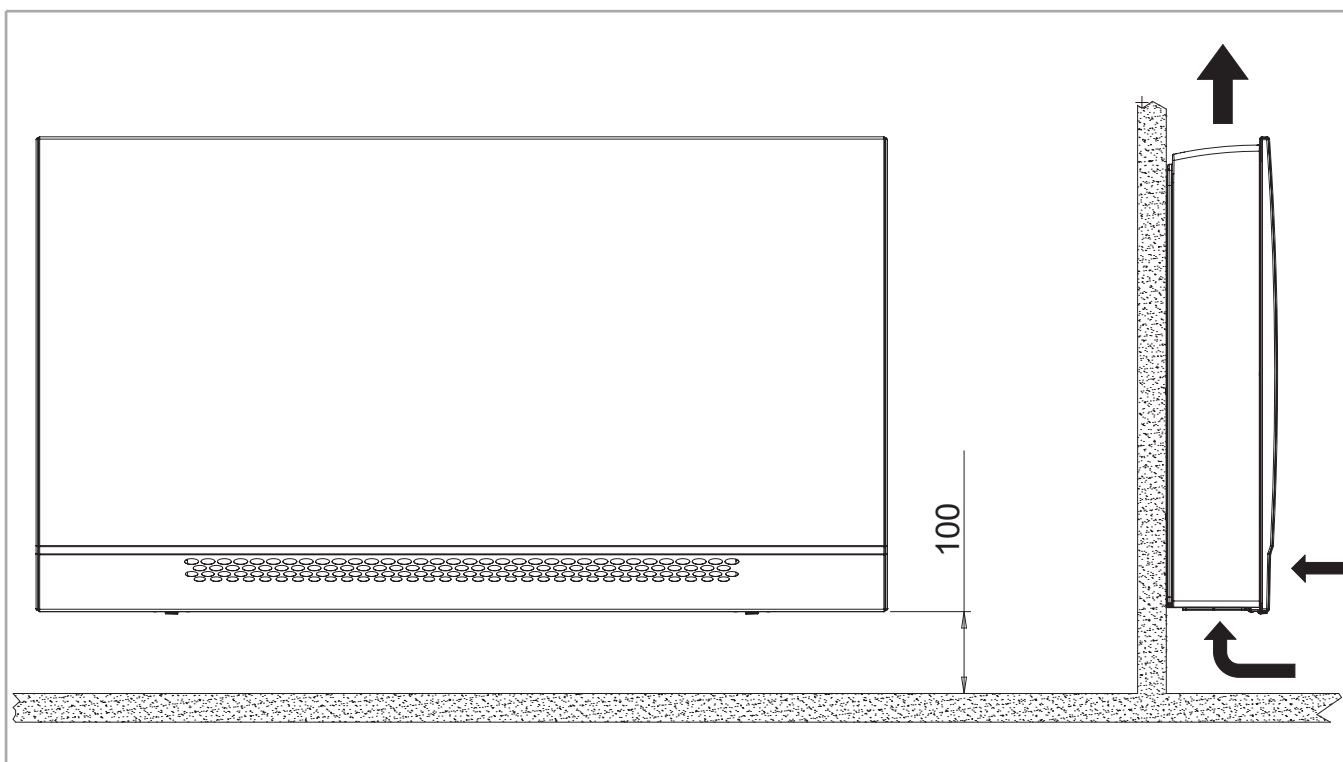

Version for concealed installation - IV

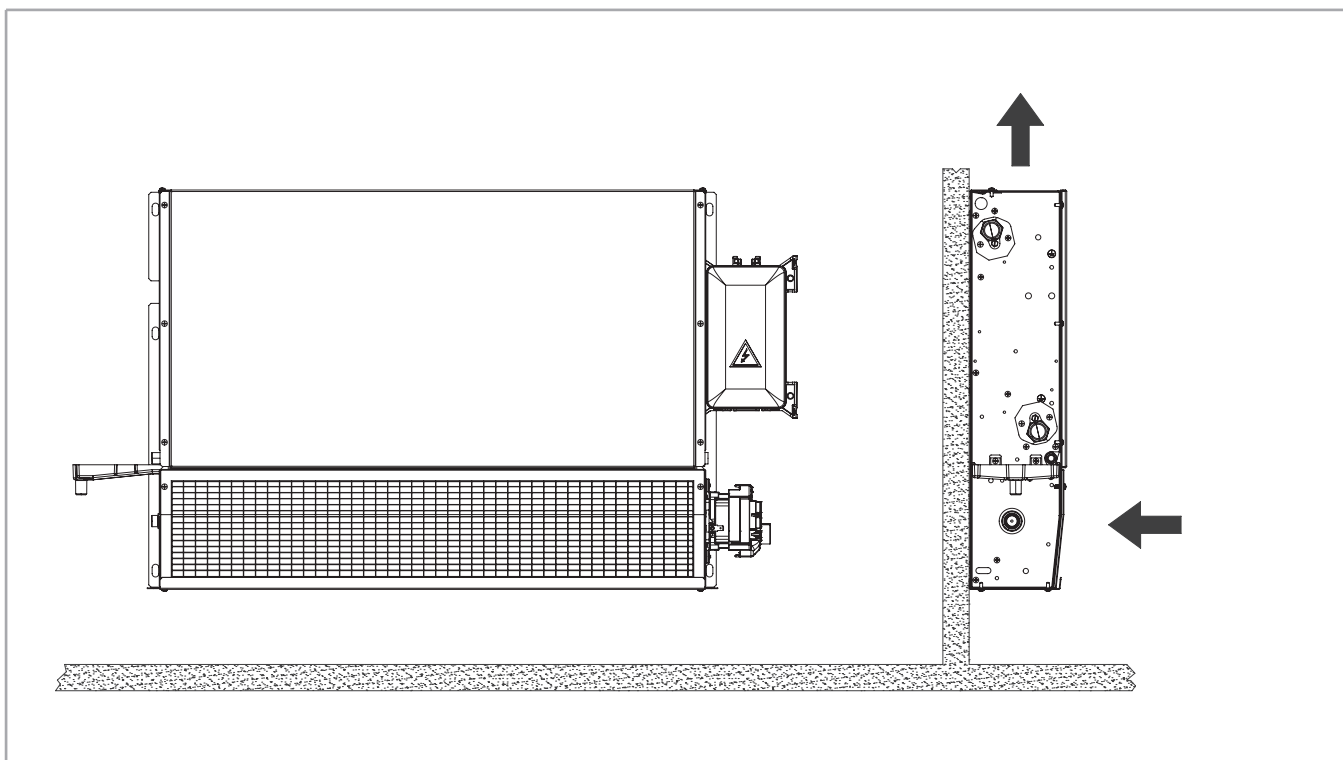

EUROVENT CERTIFICATION

The following standard rating conditions are used:

COOLING

Entering air temperature: + 27 °C d.b. + 19 °C w.b.
Water temperature: +7 °C E.W.T. +12 °C L.W.T.

HEATING

Entering air temperature: + 20 °C
Water temperature: +45 °C E.W.T. +40 °C L.W.T.

MODEL	Inverter power	CFF-ECM 10						CFF-ECM 20						CFF-ECM 30					
		1	2	3,5	5	7,5	10	1	2	3,5	5	7,5	10	1	2	3,5	5	7,5	10
Eurovent certified performances.		-	MIN (E)	-	MED (E)	-	MAX (E)	-	MIN (E)	-	MED (E)	-	MAX (E)	-	MIN (E)	-	MED (E)	-	MAX (E)
Air flow	m ³ /h	75	90	110	130	170	205	125	145	175	205	255	305	190	225	270	315	395	470
Cooling total emission (E)	kW	0,40	0,48	0,58	0,66	0,80	0,92	0,67	0,83	1,01	1,15	1,39	1,62	0,92	1,08	1,56	1,91	2,30	2,61
Cooling sensible emission (E)	kW	0,30	0,36	0,44	0,52	0,64	0,75	0,50	0,62	0,76	0,88	1,08	1,28	0,67	0,79	1,15	1,41	1,72	1,99
Heating emission (E)	kW	0,55	0,60	0,68	0,78	0,96	1,10	0,97	1,01	1,16	1,32	1,57	1,81	1,52	1,62	1,85	2,10	2,53	2,90
Dp Cooling (E)	kPa	4,9	6,0	7,5	9,1	12,0	14,7	3,1	3,6	4,3	4,9	6,1	7,4	4,5	5,4	8,6	11,5	15,2	18,6
Dp Heating (E)	kPa	6,1	6,7	8,0	9,6	13,0	16,2	3,7	3,9	4,4	5,0	6,1	7,3	7,1	7,7	9,2	11,0	14,6	18,2
Motor power input (E)	W	3,2	3,5	4,2	5,2	7,4	10,3	3,7	4,0	4,9	6,3	9,5	14,0	4,1	4,8	6,3	8,6	14,1	21,6
Sound power (Lw) (E)	dB(A)	31	33	36	40	45	50	30	33	38	42	47	52	32	34	39	43	47	53
Sound pressure (Lp) ⁽¹⁾	dB(A)	22	24	27	31	36	41	21	24	29	33	38	43	23	25	30	34	38	44

MODEL	Inverter power	CFF-ECM 40						CFF-ECM 50					
		1	2	3,5	5	7,5	10	1	2	3,5	5	7,5	10
Eurovent certified performances.		-	MIN (E)	-	MED (E)	-	MAX (E)	-	MIN (E)	-	MED (E)	-	MAX (E)
Air flow	m ³ /h	220	260	320	380	480	575	255	300	365	430	535	645
Cooling total emission (E)	kW	1,14	1,45	2,06	2,50	2,97	3,36	1,44	1,95	2,55	2,92	3,37	3,81
Cooling sensible emission (E)	kW	0,82	1,05	1,48	1,80	2,17	2,49	1,04	1,40	1,82	2,10	2,47	2,83
Heating emission (E)	kW	1,79	1,91	2,23	2,58	3,13	3,62	2,19	2,25	2,61	3,00	3,60	4,20
Dp Cooling (E)	kPa	7,3	10,2	17,3	23,7	31,7	39,1	4,6	6,4	9,1	11,2	13,9	16,9
Dp Heating (E)	kPa	11,7	12,9	16,3	20,6	28,3	36,2	6,4	6,6	8,0	9,7	12,8	16,2
Motor power input (E)	W	4,7	5,4	7,2	9,9	16,4	25,4	5,3	6,1	8,2	11,4	19,0	29,5
Sound power (Lw) (E)	dB(A)	33	37	41	45	51	55	34	38	42	46	51	55
Sound pressure (Lp) ⁽¹⁾	dB(A)	24	28	32	36	42	46	25	29	33	37	42	46

(E) Eurovent certified performance.

(1) The sound pressure levels are 9 dB (A) lower than the sound power levels, apply to the reverberant field of a 100 m³ room and a reverberation time of 0.5 sec.

COOLING EMISSION

Entering air temperature: 27 °C – R.H.: 50%

Model	Vdc	Qv m³/h	WT: 7 / 12 °C				WT: 8 / 13 °C				WT: 10 / 15 °C				WT: 12 / 17 °C			
			Pc kW	Ps kW	Qw l/h	Dp(c) kPa	Pc kW	Ps kW	Qw l/h	Dp(c) kPa	Pc kW	Ps kW	Qw l/h	Dp(c) kPa	Pc kW	Ps kW	Qw l/h	Dp(c) kPa
CFF-ECM 10	10	205	0,99	0,73	172	16,6	0,88	0,70	154	13,9	0,69	0,66	120	9,6	0,53	0,53	93	6,7
	7,5	170	0,87	0,63	151	13,5	0,78	0,60	135	11,4	0,60	0,56	105	7,9	0,46	0,46	80	5,6
	5	130	0,72	0,51	124	10,1	0,64	0,48	111	8,6	0,50	0,45	86	6,2	0,38	0,38	65	4,5
	3,5	110	0,63	0,44	108	8,3	0,56	0,42	97	7,2	0,43	0,38	75	5,2	0,33	0,33	57	3,9
	2	90	0,52	0,36	90	6,6	0,47	0,34	81	5,8	0,36	0,31	63	4,3	0,27	0,27	47	3,4
	1	75	0,44	0,30	75	5,3	0,39	0,28	68	4,7	0,30	0,26	53	3,7	0,23	0,23	40	3,0
CFF-ECM 20	10	305	1,76	1,26	306	8,3	1,57	1,20	273	7,1	1,21	1,09	211	5,2	0,91	0,91	160	3,9
	7,5	255	1,51	1,06	261	6,7	1,34	1,01	233	5,8	1,04	0,92	180	4,4	0,78	0,78	136	3,4
	5	205	1,24	0,87	215	5,3	1,11	0,82	192	4,7	0,86	0,75	149	3,7	0,64	0,64	112	3,0
	3,5	175	1,09	0,75	188	4,6	0,97	0,71	169	4,1	0,75	0,64	130	3,3	0,56	0,56	97	2,8
	2	145	0,90	0,62	155	3,8	0,81	0,58	139	3,5	0,62	0,53	107	2,9	0,46	0,46	80	2,6
	1	125	0,72	0,50	124	3,2	0,65	0,47	112	3,0	0,50	0,43	87	2,6	0,38	0,38	66	2,4
CFF-ECM 30	10	470	2,81	1,97	488	21,0	2,53	1,86	438	17,6	1,96	1,70	341	11,9	1,48	1,48	259	7,9
	7,5	395	2,47	1,71	428	17,1	2,23	1,61	385	14,4	1,73	1,46	300	9,8	1,30	1,30	226	6,7
	5	315	2,05	1,40	355	12,7	1,86	1,32	321	10,9	1,44	1,19	248	7,6	1,07	1,07	186	5,3
	3,5	270	1,68	1,14	290	9,5	1,51	1,08	262	8,2	1,18	0,97	204	5,9	0,89	0,89	153	4,3
	2	225	1,16	0,79	201	5,8	1,05	0,75	181	5,2	0,82	0,68	142	4,0	0,63	0,63	109	3,2
	1	190	0,99	0,67	171	4,9	0,89	0,63	154	4,4	0,70	0,57	121	3,5	0,53	0,53	92	2,9
CFF-ECM 40	10	575	3,60	2,47	624	44,1	3,26	2,33	565	37,0	2,54	2,12	441	24,2	1,91	1,91	333	15,3
	7,5	480	3,18	2,16	550	35,6	2,88	2,03	498	29,9	2,24	1,83	388	19,7	1,68	1,66	292	12,5
	5	380	2,68	1,79	462	26,5	2,43	1,69	419	22,5	1,89	1,51	327	14,9	1,41	1,36	244	9,6
	3,5	320	2,21	1,47	381	19,3	2,00	1,39	346	16,5	1,56	1,24	270	11,2	1,17	1,12	202	7,4
	2	260	1,56	1,04	269	11,2	1,41	0,98	244	9,7	1,11	0,88	191	6,9	0,84	0,82	145	5,0
	1	220	1,22	0,82	211	8,0	1,11	0,77	191	7,0	0,87	0,69	150	5,2	0,66	0,66	115	3,9
CFF-ECM 50	10	645	4,10	2,81	710	18,9	3,70	2,65	641	16,0	2,87	2,40	498	10,8	2,15	2,15	376	7,3
	7,5	535	3,62	2,46	626	15,5	3,28	2,31	567	13,2	2,53	2,07	439	9,0	1,89	1,87	329	6,1
	5	430	3,14	2,10	541	12,4	2,84	1,98	491	10,7	2,20	1,75	380	7,4	1,64	1,57	283	5,2
	3,5	365	2,72	1,81	470	10,0	2,47	1,71	427	8,7	1,92	1,51	331	6,2	1,42	1,34	246	4,5
	2	300	2,09	1,40	361	7,0	1,90	1,31	328	6,2	1,48	1,17	255	4,6	1,10	1,06	190	3,5
	1	255	1,55	1,04	267	4,9	1,40	0,98	242	4,4	1,10	0,88	190	3,6	0,83	0,83	144	2,9

WT: Water temperature
Vdc: Inverter power
Qv: Air flow
Pc: Cooling total emission
Ps: Cooling sensible emission
Qw: Water flow rate
Dp(c): Dp Cooling

Entering air temperature 26 °C – R.H.: 50%

Model	Vdc	WT: 7 / 12 °C					WT: 8 / 13 °C					WT: 10 / 15 °C				WT: 12 / 17 °C			
		Qv m ³ /h	Pc kW	Ps kW	Qw l/h	Dp(c) kPa	Pc kW	Ps kW	Qw l/h	Dp(c) kPa	Pc kW	Ps kW	Qw l/h	Dp(c) kPa	Pc kW	Ps kW	Qw l/h	Dp(c) kPa	
CFF-ECM 10	10	205	0,88	0,70	153	13,8	0,78	0,68	136	11,5	0,61	0,61	106	8,0	0,46	0,46	81	5,7	
	7,5	170	0,77	0,60	134	11,3	0,68	0,58	119	9,5	0,53	0,53	92	6,7	0,40	0,40	70	4,8	
	5	130	0,64	0,48	111	8,6	0,57	0,46	98	7,3	0,43	0,43	75	5,3	0,33	0,33	57	3,9	
	3,5	110	0,56	0,42	97	7,2	0,49	0,40	85	6,1	0,38	0,37	66	4,5	0,28	0,28	49	3,5	
	2	90	0,47	0,34	81	5,7	0,41	0,33	71	5,0	0,31	0,30	55	3,8	0,23	0,23	41	3,1	
	1	75	0,39	0,28	67	4,7	0,34	0,27	60	4,2	0,26	0,25	46	3,3	0,20	0,20	34	2,8	
CFF-ECM 20	10	305	1,56	1,20	271	7,1	1,38	1,15	240	6,1	1,06	1,04	184	4,5	0,79	0,79	138	3,5	
	7,5	255	1,34	1,01	231	5,8	1,18	0,96	205	5,0	0,90	0,88	157	3,9	0,67	0,67	117	3,1	
	5	205	1,11	0,82	191	4,7	0,98	0,78	169	4,2	0,74	0,71	129	3,3	0,55	0,55	96	2,8	
	3,5	175	0,97	0,71	168	4,1	0,86	0,68	148	3,7	0,65	0,61	113	3,0	0,48	0,48	84	2,6	
	2	145	0,80	0,58	138	3,5	0,71	0,55	122	3,2	0,54	0,50	93	2,7	0,40	0,40	69	2,4	
	1	125	0,64	0,47	111	3,0	0,57	0,44	99	2,8	0,44	0,41	76	2,5	0,33	0,33	57	2,3	
CFF-ECM 30	10	470	2,51	1,87	436	17,6	2,23	1,78	387	14,5	1,71	1,62	298	9,8	1,28	1,28	224	6,6	
	7,5	395	2,22	1,62	384	14,4	1,96	1,54	340	11,9	1,50	1,39	261	8,1	1,12	1,12	195	5,6	
	5	315	1,84	1,32	318	10,8	1,63	1,25	283	9,1	1,25	1,13	216	6,3	0,93	0,93	161	4,5	
	3,5	270	1,50	1,08	260	8,1	1,34	1,02	231	6,9	1,02	0,93	177	5,0	0,76	0,76	132	3,8	
	2	225	1,04	0,75	180	5,2	0,93	0,70	160	4,6	0,72	0,66	124	3,6	0,55	0,55	95	3,0	
	1	190	0,88	0,63	153	4,4	0,79	0,59	136	3,9	0,61	0,56	106	3,2	0,46	0,46	80	2,7	
CFF-ECM 40	10	575	3,24	2,34	561	36,7	2,88	2,22	499	30,0	2,21	2,02	384	19,3	1,65	1,65	289	12,3	
	7,5	480	2,86	2,04	495	29,7	2,54	1,93	441	24,4	1,95	1,74	338	15,7	1,45	1,45	252	10,0	
	5	380	2,41	1,69	416	22,3	2,15	1,60	371	18,4	1,64	1,43	283	12,0	1,21	1,21	210	7,8	
	3,5	320	1,99	1,39	343	16,3	1,78	1,31	307	13,7	1,36	1,18	234	9,1	1,00	1,00	174	6,1	
	2	260	1,40	0,99	242	9,6	1,25	0,92	217	8,2	0,96	0,85	167	5,9	0,72	0,72	125	4,3	
	1	220	1,10	0,77	190	6,9	0,98	0,72	170	6,0	0,76	0,67	131	4,5	0,57	0,57	99	3,5	
CFF-ECM 50	10	645	3,68	2,66	637	15,9	3,26	2,52	566	13,2	2,49	2,29	434	8,9	1,86	1,86	324	6,0	
	7,5	535	3,25	2,32	563	13,1	2,88	2,19	499	10,9	2,20	1,97	382	7,5	1,63	1,63	284	5,2	
	5	430	2,82	1,98	487	10,6	2,50	1,87	433	8,9	1,91	1,65	330	6,2	1,40	1,40	243	4,4	
	3,5	365	2,45	1,71	424	8,7	2,18	1,61	377	7,4	1,66	1,42	287	5,3	1,22	1,22	211	3,9	
	2	300	1,88	1,32	325	6,1	1,68	1,24	291	5,4	1,28	1,11	221	4,0	0,94	0,94	164	3,2	
	1	255	1,39	0,98	240	4,4	1,24	0,92	215	4,0	0,96	0,85	165	3,2	0,72	0,72	124	2,7	

WT: Water temperature
Vdc: Inverter power
Qv: Air flow
Pc: Cooling total emission
Ps: Cooling sensible emission
Qw: Water flow rate
Dp(c): Dp Cooling

Entering air temperature: 25 °C – R.H.: 50%

Model	Vdc	WT: 7 / 12 °C					WT: 8 / 13 °C				WT: 10 / 15 °C				WT: 12 / 17 °C			
		Qv m ³ /h	Pc kW	Ps kW	Qw l/h	Dp(c) kPa	Pc kW	Ps kW	Qw l/h	Dp(c) kPa	Pc kW	Ps kW	Qw l/h	Dp(c) kPa	Pc kW	Ps kW	Qw l/h	Dp(c) kPa
CFF-ECM 10	10	205	0,78	0,68	136	11,5	0,69	0,65	120	9,6	0,53	0,53	93	6,7	0,45	0,45	79	5,5
	7,5	170	0,68	0,58	119	9,5	0,60	0,56	105	8,0	0,46	0,46	81	5,7	0,39	0,39	68	4,7
	5	130	0,56	0,46	98	7,3	0,50	0,44	86	6,2	0,38	0,38	66	4,5	0,30	0,30	52	3,6
	3,5	110	0,49	0,40	85	6,1	0,43	0,38	75	5,2	0,33	0,33	57	4,0	0,25	0,25	43	3,2
	2	90	0,41	0,33	71	5,0	0,36	0,31	62	4,3	0,27	0,27	48	3,4	0,20	0,20	35	2,8
	1	75	0,34	0,27	59	4,1	0,30	0,26	52	3,7	0,23	0,23	40	3,0	0,17	0,17	30	2,6
CFF-ECM 20	10	305	1,38	1,14	239	6,0	1,21	1,09	211	5,2	0,92	0,92	160	3,9	0,77	0,77	134	3,4
	7,5	255	1,18	0,96	204	5,0	1,03	0,92	180	4,4	0,78	0,78	136	3,5	0,62	0,62	109	3,0
	5	205	0,97	0,78	168	4,2	0,86	0,74	148	3,7	0,65	0,65	112	3,0	0,49	0,49	85	2,6
	3,5	175	0,85	0,68	147	3,7	0,75	0,64	129	3,3	0,56	0,56	98	2,8	0,42	0,42	72	2,5
	2	145	0,70	0,55	122	3,2	0,62	0,53	107	2,9	0,47	0,47	81	2,6	0,34	0,34	60	2,3
	1	125	0,57	0,44	98	2,8	0,50	0,42	86	2,6	0,38	0,38	66	2,4	0,28	0,28	49	2,2
CFF-ECM 30	10	470	2,22	1,78	386	14,5	1,96	1,69	340	11,9	1,49	1,49	260	8,0	1,11	1,11	194	5,5
	7,5	395	1,95	1,54	339	11,9	1,72	1,46	298	9,8	1,30	1,30	227	6,7	0,97	0,97	169	4,8
	5	315	1,63	1,26	281	9,1	1,43	1,19	247	7,6	1,08	1,08	187	5,3	0,80	0,80	139	3,9
	3,5	270	1,33	1,02	230	6,9	1,17	0,97	203	5,9	0,89	0,89	154	4,3	0,66	0,66	114	3,4
	2	225	0,92	0,70	159	4,5	0,82	0,68	141	4,0	0,63	0,63	109	3,3	0,47	0,47	82	2,8
	1	190	0,78	0,59	136	3,9	0,69	0,57	120	3,5	0,53	0,53	92	2,9	0,40	0,40	70	2,6
CFF-ECM 40	10	575	2,86	2,22	497	29,9	2,53	2,11	439	24,2	1,92	1,92	334	15,5	1,43	1,43	249	9,9
	7,5	480	2,54	1,94	439	24,3	2,23	1,83	387	19,7	1,69	1,65	293	12,6	1,25	1,25	217	8,2
	5	380	2,14	1,60	370	18,4	1,88	1,51	325	14,9	1,42	1,35	245	9,7	1,04	1,04	180	6,4
	3,5	320	1,77	1,31	305	13,6	1,55	1,24	268	11,2	1,17	1,12	203	7,5	0,86	0,86	149	5,1
	2	260	1,25	0,93	215	8,2	1,10	0,88	190	6,9	0,84	0,82	145	5,0	0,63	0,63	109	3,8
	1	220	0,98	0,73	169	6,0	0,86	0,69	149	5,2	0,66	0,65	115	4,0	0,50	0,50	86	3,2
CFF-ECM 50	10	645	3,25	2,53	564	33,2	2,86	2,40	496	30,8	2,16	2,16	377	23,3	1,60	1,60	280	13,1
	7,5	535	2,87	2,20	497	27,3	2,52	2,08	437	26,0	1,90	1,87	330	20,0	1,40	1,40	244	11,2
	5	430	2,49	1,87	431	22,5	2,19	1,76	379	21,2	1,64	1,56	284	17,0	1,20	1,20	208	9,3
	3,5	365	2,17	1,61	375	18,7	1,91	1,51	329	17,6	1,43	1,34	247	14,5	1,04	1,04	180	7,7
	2	300	1,67	1,24	289	14,1	1,47	1,17	254	13,2	1,10	1,05	191	11,4	0,81	0,81	140	5,9
	1	255	1,24	0,92	214	11,1	1,09	0,88	189	10,9	0,83	0,82	144	10,2	0,62	0,62	108	4,7

WT: Water temperature
Vdc: Inverter power
Qv: Air flow
Pc: Cooling total emission
Ps: Cooling sensible emission
Qw: Water flow rate
Dp(c): Dp Cooling

HEATING EMISSION

Entering air temperature: 18 °C

Model	Vdc	Qv m ³ /h	WT: 70 / 60 °C			WT: 60 / 50 °C			WT: 50 / 40 °C			WT: 50 / 45 °C			WT: 45 / 40 °C		
			Ph kW	Qw l/h	Dp(h) kPa	Ph kW	Qw l/h	Dp(h) kPa	Ph kW	Qw l/h	Dp(h) kPa	Ph kW	Qw l/h	Dp(h) kPa	Ph kW	Qw l/h	Dp(h) kPa
CFF-ECM 10	10	205	2,35	202	16,7	1,83	157	11,7	1,31	113	7,5	1,47	252	25,3	1,21	208	18,8
	7,5	170	2,03	175	13,3	1,59	136	9,5	1,14	98	6,3	1,27	218	19,9	1,05	180	14,9
	5	130	1,66	142	9,8	1,30	111	7,2	0,93	80	5,0	1,03	178	14,4	0,86	147	11,0
	3,5	110	1,45	125	8,1	1,14	98	6,1	0,82	71	4,4	0,90	155	11,7	0,75	129	9,1
	2	90	1,26	108	6,8	0,99	85	5,2	0,72	62	3,9	0,79	135	9,6	0,65	112	7,5
	1	75	1,17	101	6,2	0,92	79	4,8	0,67	57	3,6	0,73	126	8,6	0,61	104	6,8
CFF-ECM 20	10	305	3,84	330	7,5	3,00	258	5,6	2,16	186	4,1	2,40	412	10,6	1,98	341	8,3
	7,5	255	3,33	287	6,2	2,61	225	4,8	1,88	162	3,6	2,08	358	8,7	1,72	296	6,8
	5	205	2,79	240	5,1	2,19	188	4,1	1,59	136	3,2	1,74	299	6,9	1,44	248	5,5
	3,5	175	2,45	211	4,4	1,93	166	3,6	1,40	120	2,9	1,53	263	5,8	1,27	218	4,8
	2	145	2,15	185	3,9	1,69	145	3,3	1,23	106	2,7	1,34	230	5,0	1,11	191	4,2
	1	125	2,05	176	3,8	1,61	139	3,2	1,17	101	2,7	1,27	219	4,8	1,06	182	4,0
CFF-ECM 30	10	470	6,14	528	18,6	4,83	415	13,1	3,50	301	8,5	3,83	659	28,2	3,18	547	21,1
	7,5	395	5,34	459	14,9	4,20	362	10,7	3,06	263	7,1	3,33	572	22,3	2,76	475	16,8
	5	315	4,44	382	11,2	3,50	301	8,2	2,55	220	5,7	2,76	475	16,5	2,30	395	12,6
	3,5	270	3,90	336	9,3	3,08	265	6,9	2,25	194	4,9	2,43	417	13,5	2,02	347	10,4
	2	225	3,42	295	7,8	2,71	233	5,9	1,98	171	4,3	2,13	366	11,1	1,77	305	8,7
	1	190	3,21	276	7,1	2,54	218	5,5	1,86	160	4,1	1,99	343	10,1	1,66	286	7,9
CFF-ECM 40	10	575	7,64	657	36,8	6,02	518	25,4	4,39	378	15,8	4,76	819	56,9	3,95	680	42,1
	7,5	480	6,60	567	28,7	5,21	448	20,1	3,81	328	12,7	4,11	707	44,1	3,42	588	32,8
	5	380	5,44	468	20,9	4,30	370	14,8	3,15	271	9,6	3,38	582	31,7	2,82	485	23,8
	3,5	320	4,70	405	16,5	3,72	320	11,9	2,74	235	7,9	2,92	503	24,8	2,44	419	18,8
	2	260	4,04	347	13,0	3,20	275	9,5	2,36	203	6,5	2,51	431	19,3	2,09	360	14,7
	1	220	3,78	325	11,8	3,00	258	8,7	2,21	190	6,0	2,35	404	17,4	1,96	337	13,3
CFF-ECM 50	10	645	8,87	763	16,5	6,99	601	11,8	5,10	439	7,7	5,52	950	24,9	4,59	790	18,7
	7,5	535	7,60	654	13,0	6,00	516	9,4	4,39	377	6,4	4,73	814	19,3	3,94	677	14,7
	5	430	6,32	544	9,9	5,00	430	7,3	3,67	315	5,2	3,93	676	14,4	3,28	563	11,1
	3,5	365	5,49	472	8,1	4,35	374	6,2	3,20	275	4,5	3,41	587	11,6	2,85	489	9,1
	2	300	4,75	409	6,7	3,77	324	5,2	2,78	239	3,9	2,95	507	9,4	2,46	423	7,4
	1	255	4,62	397	6,5	3,67	315	5,1	2,70	232	3,8	2,87	493	9,0	2,39	412	7,2

WT: Water temperature
Vdc: Inverter power
Qv: Air flow
Ph: Heating emission
Qw: Water flow rate
Dp(h): Dp Heating

Radiant panel heating emission

Model	Ph* kW
CFF-ECM-MV-R 10	0,06
CFF-ECM-MV-R 20	0,09
CFF-ECM-MV-R 30	0,12
CFF-ECM-MV-R 40	0,15
CFF-ECM-MV-R 50	0,18

*Additional emission once the panel is activated

Entering air temperature: 20 °C

Model	Vdc	WT: 70 / 60 °C				WT: 60 / 50 °C			WT: 50 / 40 °C			WT: 50 / 45 °C			WT: 45 / 40 °C		
		Qv m ³ /h	Ph kW	Qw l/h	Dp(h) kPa	Ph kW	Qw l/h	Dp(h) kPa	Ph kW	Qw l/h	Dp(h) kPa	Ph kW	Qw l/h	Dp(h) kPa	Ph kW	Qw l/h	Dp(h) kPa
CFF-ECM 10	10	205	2,23	192	15,4	1,72	148	10,7	1,20	103	6,7	1,36	234	22,3	1,10	190	16,2
	7,5	170	1,93	166	12,3	1,49	128	8,7	1,04	90	5,7	1,18	202	17,6	0,96	165	13,0
	5	130	1,58	136	9,2	1,22	105	6,7	0,86	74	4,6	0,96	165	12,8	0,78	134	9,6
	3,5	110	1,38	119	7,6	1,07	92	5,7	0,75	65	4,0	0,84	144	10,5	0,68	118	8,0
	2	90	1,20	103	6,4	0,93	80	4,9	0,66	57	3,6	0,73	125	8,6	0,60	102	6,7
	1	75	1,12	96	5,8	0,87	74	4,5	0,61	53	3,4	0,68	116	7,8	0,55	95	6,1
CFF-ECM 20	10	305	3,66	315	7,0	2,82	243	5,2	1,98	170	3,8	2,22	382	9,5	1,81	311	7,3
	7,5	255	3,18	273	5,9	2,46	211	4,5	1,73	149	3,4	1,93	332	7,8	1,57	270	6,1
	5	205	2,66	229	4,8	2,06	177	3,8	1,46	125	3,0	1,61	278	6,2	1,32	227	5,0
	3,5	175	2,34	201	4,2	1,81	156	3,5	1,29	111	2,8	1,42	244	5,3	1,16	199	4,4
	2	145	2,05	176	3,8	1,59	137	3,2	1,13	97	2,6	1,24	213	4,6	1,01	174	3,9
	1	125	1,95	168	3,6	1,52	130	3,1	1,08	93	2,6	1,18	203	4,4	0,97	166	3,7
CFF-ECM 30	10	470	5,85	503	17,2	4,54	391	12,0	3,23	277	7,6	3,55	611	24,9	2,90	499	18,2
	7,5	395	5,09	438	13,8	3,96	340	9,8	2,82	242	6,4	3,09	531	19,8	2,53	434	14,6
	5	315	4,23	364	10,5	3,30	283	7,6	2,35	202	5,2	2,56	441	14,7	2,10	361	11,0
	3,5	270	3,72	320	8,7	2,90	249	6,4	2,08	179	4,5	2,25	387	12,1	1,85	318	9,2
	2	225	3,26	281	7,3	2,55	219	5,5	1,83	157	4,0	1,98	340	10,0	1,62	279	7,7
	1	190	3,06	263	6,7	2,39	206	5,1	1,72	148	3,8	1,85	318	9,1	1,52	261	7,1
CFF-ECM 40	10	575	7,27	626	33,8	5,67	487	23,0	4,05	348	13,9	4,42	759	50,0	3,62	622	36,2
	7,5	480	6,29	541	26,5	4,90	422	18,2	3,51	302	11,2	3,81	656	38,9	3,13	538	28,3
	5	380	5,18	446	19,3	4,05	348	13,5	2,91	250	8,6	3,14	540	28,0	2,58	443	20,6
	3,5	320	4,48	386	15,3	3,51	302	10,9	2,52	217	7,1	2,71	467	22,0	2,23	384	16,3
	2	260	3,85	331	12,1	3,02	259	8,8	2,18	187	5,9	2,33	400	17,2	1,91	329	12,9
	1	220	3,61	310	11,0	2,83	243	8,0	2,04	176	5,5	2,18	375	15,5	1,79	309	11,7
CFF-ECM 50	10	645	8,45	727	15,3	6,58	566	10,8	4,70	404	7,0	5,12	881	22,0	4,20	722	16,2
	7,5	535	7,24	623	12,1	5,65	486	8,7	4,04	348	5,8	4,39	755	17,1	3,60	619	12,8
	5	430	6,03	518	9,2	4,71	405	6,8	3,38	291	4,7	3,65	628	12,8	3,00	515	9,7
	3,5	365	5,24	450	7,6	4,10	352	5,7	2,95	254	4,1	3,17	545	10,4	2,61	448	8,0
	2	300	4,53	390	6,3	3,55	305	4,9	2,56	220	3,7	2,74	471	8,5	2,25	388	6,6
	1	255	4,40	379	6,1	3,45	297	4,7	2,49	214	3,6	2,66	458	8,2	2,19	377	6,4

WT: Water temperature
Vdc: Inverter power
Qv: Air flow
Ph: Heating emission
Qw: Water flow rate
Dp(h): Dp Heating

Radiant panel heating emission

Model	Ph* kW
CFF-ECM-MV-R 10	0,06
CFF-ECM-MV-R 20	0,09
CFF-ECM-MV-R 30	0,12
CFF-ECM-MV-R 40	0,15
CFF-ECM-MV-R 50	0,18

*Additional emission once the panel is activated

Entering air temperature: 22 °C

Model	Vdc	WT: 70 / 60 °C				WT: 60 / 50 °C				WT: 50 / 40 °C			WT: 50 / 45 °C			WT: 45 / 40 °C		
		Qv m ³ /h	Ph kW	Qw l/h	Dp(h) kPa	Ph kW	Qw l/h	Dp(h) kPa	Ph kW	Qw l/h	Dp(h) kPa	Ph kW	Qw l/h	Dp(h) kPa	Ph kW	Qw l/h	Dp(h) kPa	
CFF-ECM 10	10	205	2,12	183	14,2	1,61	139	9,7	1,09	94	6,0	1,25	216	19,5	1,00	172	13,9	
	7,5	170	1,84	158	11,4	1,40	120	8,0	0,95	82	5,1	1,08	186	15,5	0,87	149	11,2	
	5	130	1,50	129	8,5	1,14	98	6,1	0,78	67	4,2	0,88	152	11,3	0,71	122	8,4	
	3,5	110	1,31	113	7,1	1,00	86	5,3	0,69	59	3,7	0,77	133	9,3	0,62	106	7,0	
	2	90	1,14	98	6,0	0,87	75	4,6	0,60	52	3,4	0,67	116	7,7	0,54	93	5,9	
	1	75	1,06	91	5,5	0,81	70	4,2	0,56	48	3,2	0,62	107	7,0	0,50	86	5,4	
CFF-ECM 20	10	305	3,48	299	6,6	2,64	227	4,9	1,81	155	3,5	2,05	352	8,5	1,64	282	6,4	
	7,5	255	3,02	259	5,5	2,30	198	4,2	1,58	136	3,2	1,78	306	7,0	1,42	245	5,4	
	5	205	2,53	217	4,6	1,93	166	3,6	1,33	114	2,9	1,49	256	5,7	1,19	205	4,5	
	3,5	175	2,22	191	4,0	1,70	146	3,3	1,17	101	2,7	1,31	225	4,9	1,05	180	4,0	
	2	145	1,94	167	3,6	1,49	128	3,0	1,03	89	2,6	1,14	197	4,3	0,92	158	3,6	
	1	125	1,85	159	3,5	1,42	122	2,9	0,99	85	2,5	1,09	188	4,1	0,88	151	3,4	
CFF-ECM 30	10	470	5,56	478	15,9	4,26	366	10,9	2,95	253	6,7	3,28	564	21,8	2,63	453	15,6	
	7,5	395	4,84	416	12,8	3,71	319	8,9	2,58	221	5,7	2,85	490	17,4	2,29	394	12,6	
	5	315	4,02	346	9,7	3,09	266	7,0	2,15	185	4,7	2,37	407	13,0	1,91	328	9,6	
	3,5	270	3,54	304	8,1	2,72	234	6,0	1,90	163	4,2	2,08	358	10,7	1,68	288	8,0	
	2	225	3,11	267	6,9	2,40	206	5,1	1,68	144	3,7	1,83	314	8,9	1,47	253	6,8	
	1	190	2,91	250	6,3	2,25	193	4,8	1,57	135	3,5	1,71	294	8,1	1,38	237	6,2	
CFF-ECM 40	10	575	6,92	595	31,1	5,32	457	20,8	3,70	319	12,1	4,08	701	43,6	3,28	564	30,6	
	7,5	480	5,98	514	24,4	4,60	396	16,5	3,22	277	9,9	3,52	606	33,9	2,84	488	24,0	
	5	380	4,93	424	17,8	3,81	327	12,3	2,67	229	7,6	2,90	499	24,5	2,34	403	17,6	
	3,5	320	4,27	367	14,2	3,30	283	9,9	2,32	199	6,4	2,51	431	19,3	2,03	348	14,0	
	2	260	3,66	315	11,2	2,83	244	8,0	2,00	172	5,3	2,15	370	15,1	1,74	299	11,1	
	1	220	3,43	295	10,2	2,66	229	7,4	1,88	161	5,0	2,02	347	13,7	1,63	281	10,1	
CFF-ECM 50	10	645	8,04	691	14,1	6,18	531	9,8	4,30	370	6,2	4,73	814	19,3	3,81	655	13,9	
	7,5	535	6,89	592	11,2	5,31	456	8,0	3,70	318	5,2	4,05	697	15,1	3,27	562	11,1	
	5	430	5,73	493	8,6	4,43	381	6,3	3,10	267	4,3	3,37	580	11,4	2,72	468	8,5	
	3,5	365	4,98	428	7,1	3,85	331	5,3	2,70	233	3,8	2,93	504	9,3	2,37	407	7,1	
	2	300	4,31	371	6,0	3,34	287	4,6	2,35	202	3,4	2,53	435	7,6	2,05	352	5,9	
	1	255	4,19	361	5,8	3,25	279	4,5	2,29	197	3,4	2,46	423	7,3	1,99	343	5,7	

WT: Water temperature
Vdc: Inverter power
Qv: Air flow
Ph: Heating emission
Qw: Water flow rate
Dp(h): Dp Heating

Radiant panel heating emission

Model	Ph* kW
CFF-ECM-MV-R 10	0,06
CFF-ECM-MV-R 20	0,09
CFF-ECM-MV-R 30	0,12
CFF-ECM-MV-R 40	0,15
CFF-ECM-MV-R 50	0,18

***Additional emission once the panel is activated**

WATER SIDE PRESSURE DROP

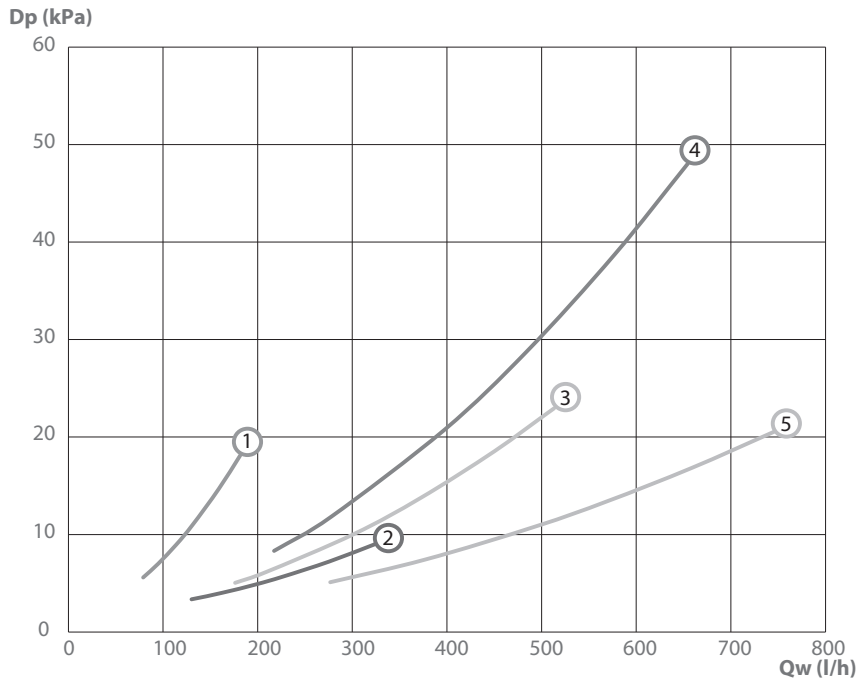

Dp = pressure drop
 Qw = water flow rate
 1 = CFF-ECM 10
 2 = CFF-ECM 20
 3 = CFF-ECM 30
 4 = CFF-ECM 40
 5 = CFF-ECM 50

Pressure drop for mean water temperature of **10 °C**; for different temperatures multiply the pressure drop figure by the **K** correction factors in the table.

	Mean water temperature (°C)						
	20	30	40	50	60	70	80
K correction factor	0,94	0,90	0,86	0,82	0,78	0,74	0,70

OPERATION LIMITS

Description		UoM	Value
Water flow	Coil maximum working pressure	bars	16
		kPa	1600
	Lowest water inlet temperature	°C	6
	Highest water inlet temperature	°C	85
Power supply	Single-phase rated operating voltage	V/Hz	230/50

Coils water flow limits

2 row coil

Model		CFF-ECM 10	CFF-ECM 20	CFF-ECM 30	CFF-ECM 40	CFF-ECM 50
Water flow rate Min.	l/h	40	80		120	
Water flow rate Max.	l/h	200	350	500	600	800

Motor max. absorption

Model		CFF-ECM 10	CFF-ECM 20	CFF-ECM 30	CFF-ECM 40	CFF-ECM 50
Motor absorption	W	10,5	14,0	21,5	25,5	30,0
Current absorbed	A	0,15	0,18	0,25	0,28	0,30

Motor max. absorption plus radiant panel

Model		CFF-ECM-MV-R 10	CFF-ECM-MV-R 20	CFF-ECM-MV-R 30	CFF-ECM-MV-R 40	CFF-ECM-MV-R 50
Rating	W	70,5	104,0	141,5	175,5	210,0
Current absorbed	A	0,45	0,58	0,85	0,98	1,10



DIMENSIONS

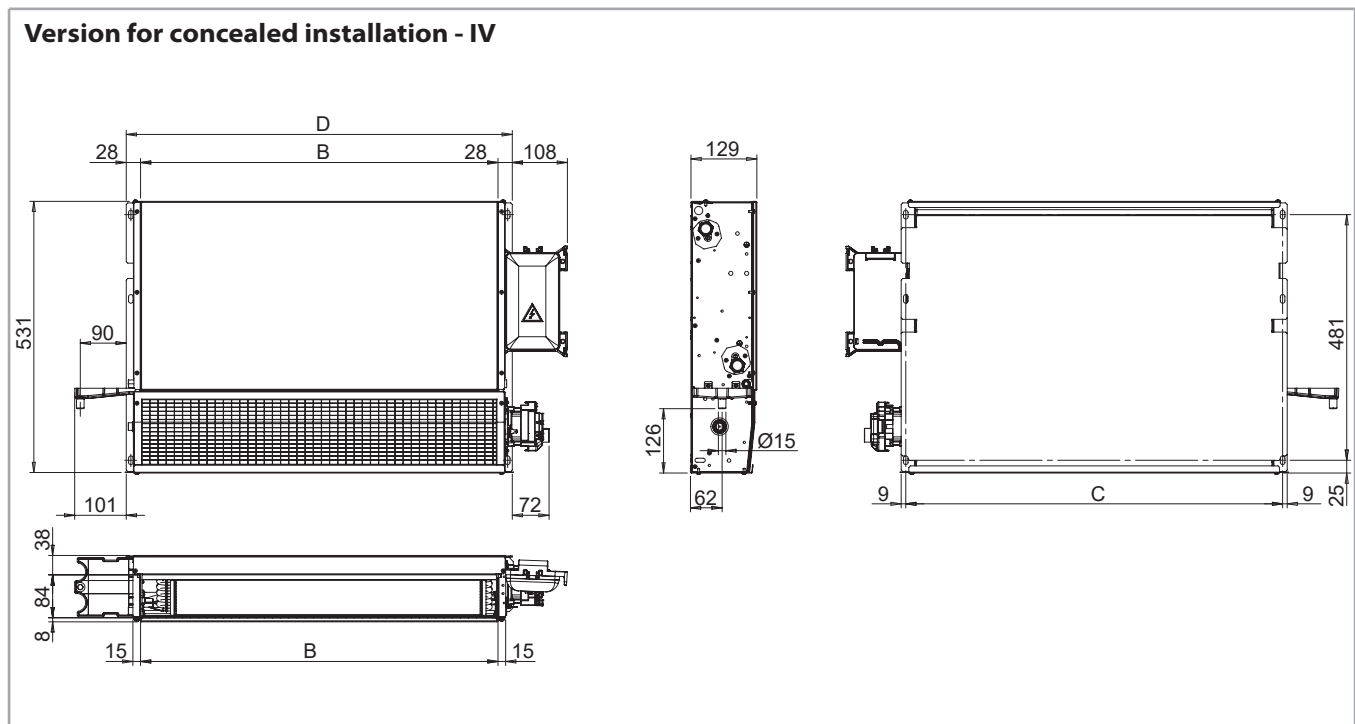
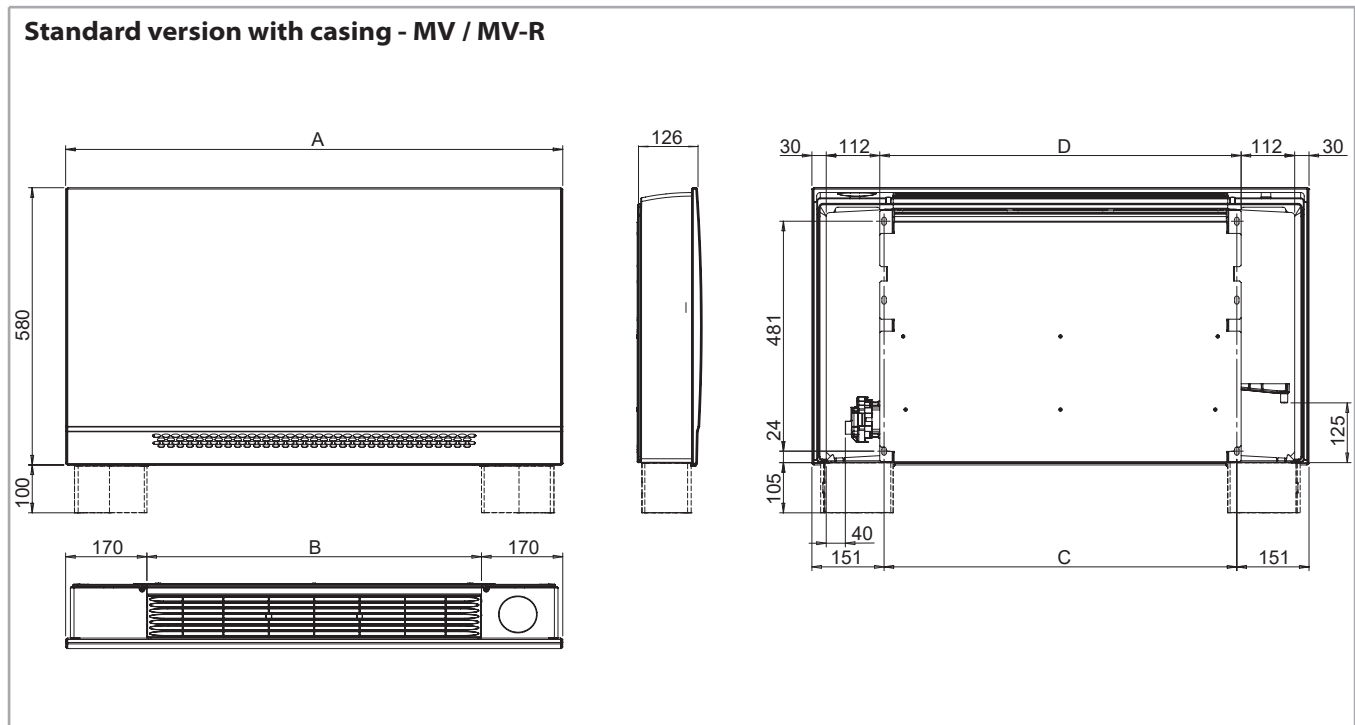

Model		CFF-ECM 10	CFF-ECM 20	CFF-ECM 30	CFF-ECM 40	CFF-ECM 50
A	mm	640	840	1040	1240	1440
B	mm	300	500	700	900	1100
C	mm	338	538	738	938	1138
D	mm	356	556	756	956	1156

Hydraulic connections

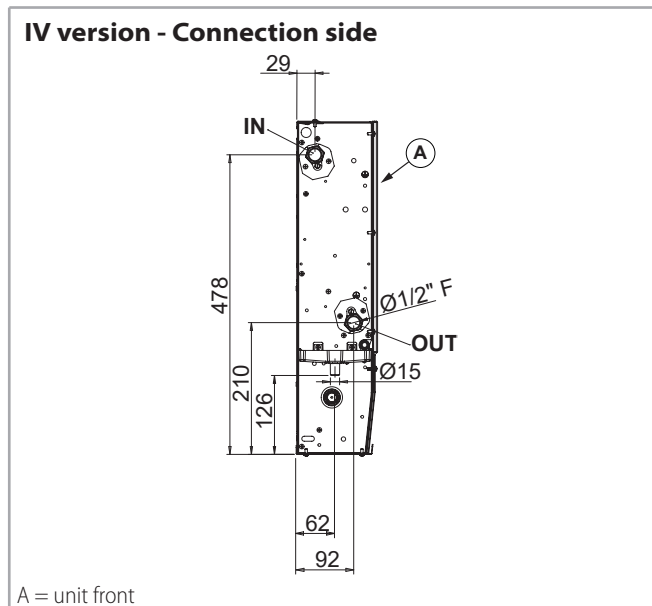
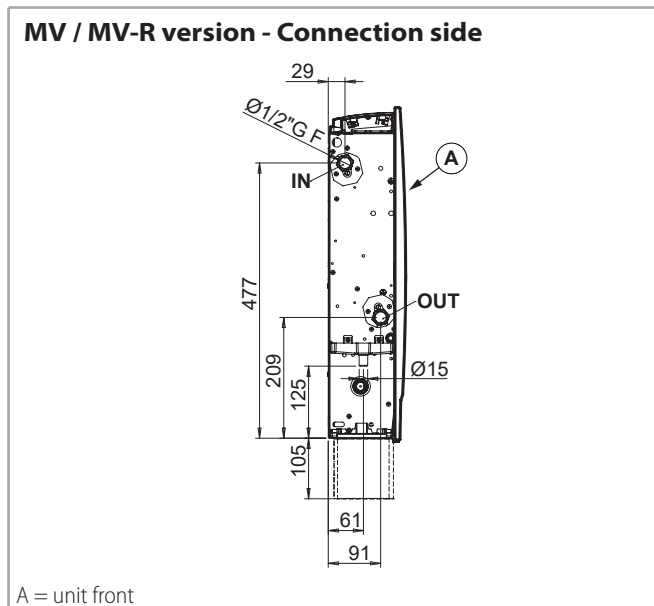

Packed unit

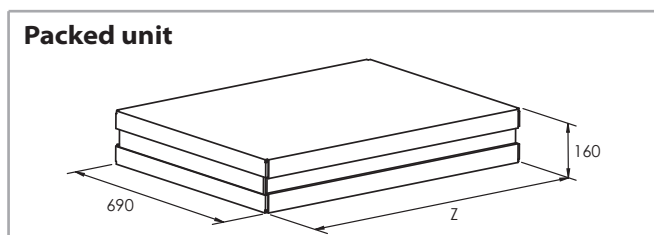

Model	CFF-ECM 10	CFF-ECM 20	CFF-ECM 30	CFF-ECM 40	CFF-ECM 50	
Z	mm	720	920	1120	1320	1520

Weight

The table of the weight is related to the standard versions with casing in the basic configuration without

control and without valves; the weights can change for those units completed with control and/or valve.

Standard version with MV casing

Model		CFF-ECM-MV 10	CFF-ECM-MV 20	CFF-ECM-MV 30	CFF-ECM-MV 40	CFF-ECM-MV 50
Weight with packaging	kg	11,6	14,9	18,5	21,9	25,7
Weight without packaging	kg	10,1	13,2	16,4	19,6	23,0

Version with MV-R radiant panel

Model		CFF-ECM-MV-R 10	CFF-ECM-MV-R 20	CFF-ECM-MV-R 30	CFF-ECM-MV-R 40	CFF-ECM-MV-R 50
Weight with packaging	kg	12,1	16,1	20,3	24,9	29,4
Weight without packaging	kg	10,5	14,2	18,1	22,5	26,6

IV version for concealed installation

Model		CFF-ECM-IV 10	CFF-ECM-IV 20	CFF-ECM-IV 30	CFF-ECM-IV 40	CFF-ECM-IV 50
Weight with packaging	kg	10,1	13,6	17,3	20,9	24,9
Weight without packaging	kg	8,5	11,7	15,1	18,5	22,1

Water content

Model		CFF-ECM 10	CFF-ECM 20	CFF-ECM 30	CFF-ECM 40	CFF-ECM 50
Water content	l	0,4	0,7	1,1	1,4	1,7

VALVES

The CFF units are available either in the versions with mounted valves and in the versions without valves. The features and the installation dimensions of the valves are shown as follows and are valid either for the

versions with mounted valves and for the versions with valves installed on site.

2 way valve

2 way valve ON-OFF 230 V

Model	Kvs m ³ /h	Dp max ⁽¹⁾ kPa	Valve connections (male) Ø	NOT FITTED	
				Code	ID
10-20-30-40-50	1,7	50	1/2"	9071090W	V2-F

(1) Maximum pressure difference for valve to close

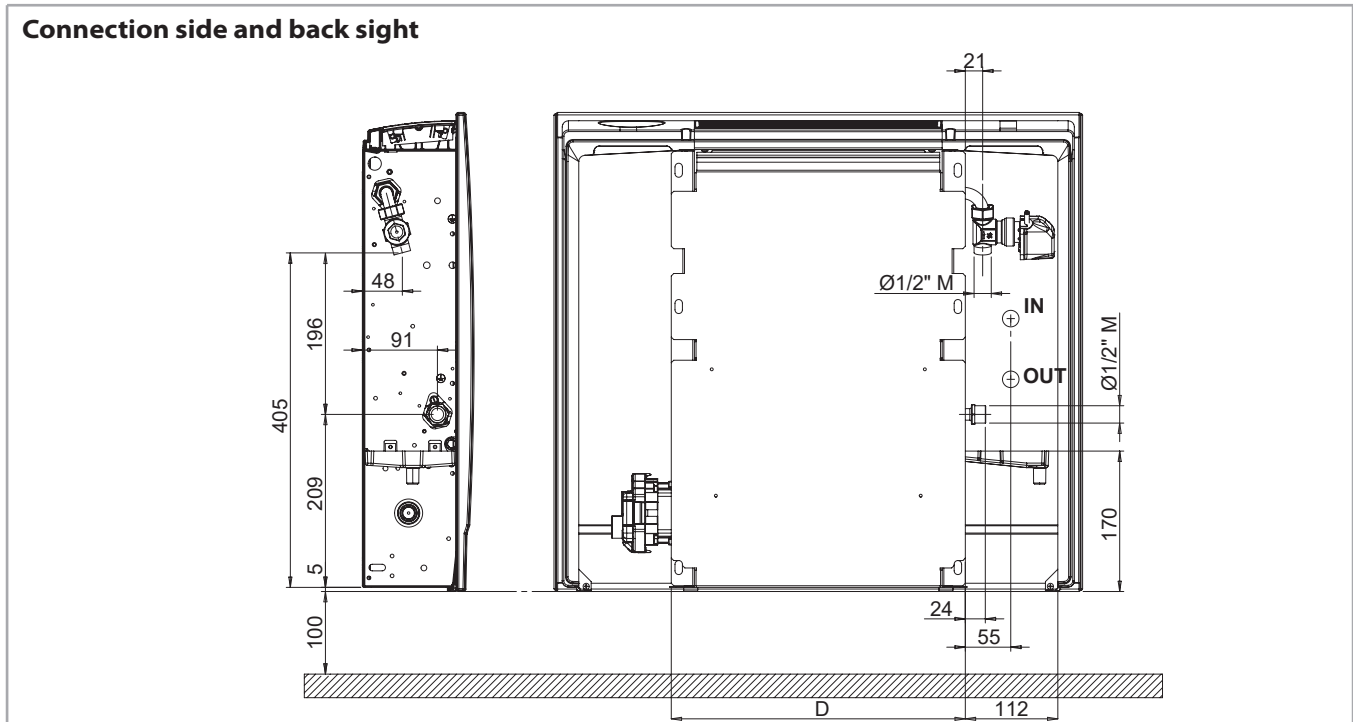

Model	CFF-ECM 10	CFF-ECM 20	CFF-ECM 30	CFF-ECM 40	CFF-ECM 50	
D	mm	356	556	756	956	1156

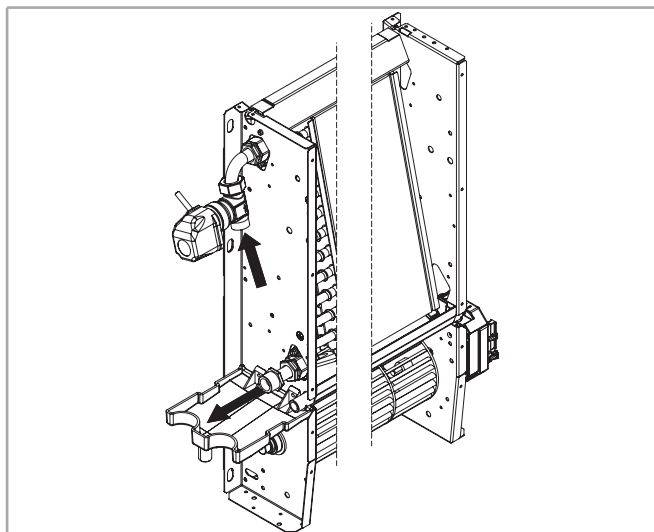

2 way valves pressure drop

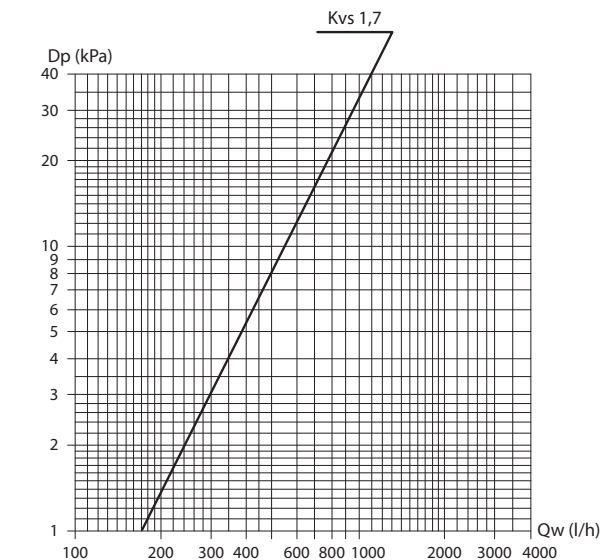

Dp = pressure drop
Qw = water flow rate

3 way valves

3 way water valve ON-OFF 230 V and mounting kit.

Model	Kvs m ³ /h	Dp max ⁽¹⁾ kPa	Pipe kit connection (male) Ø	NOT FITTED	
				Code	ID
10-20-30-40-50	1,6	50	1/2"	9071091W	V3-F

(1) Maximum pressure difference for valve to close

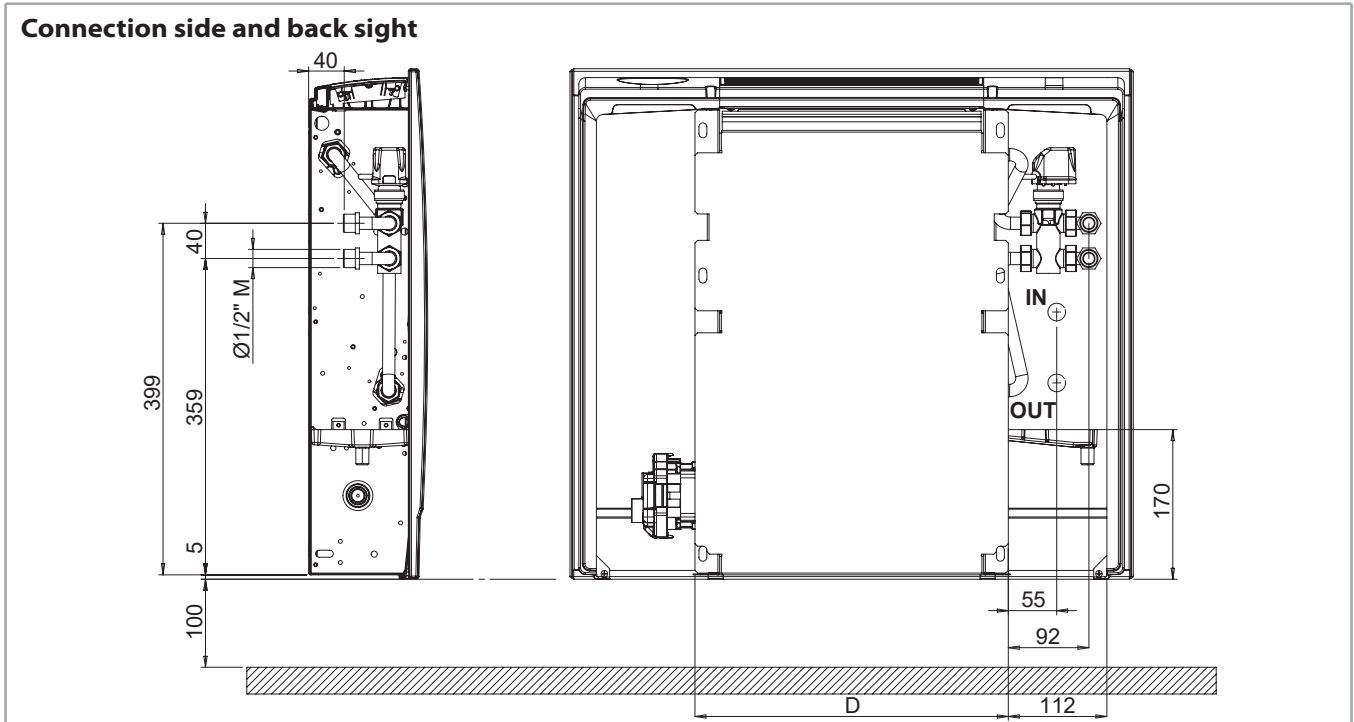

Model	CFF-ECM 10	CFF-ECM 20	CFF-ECM 30	CFF-ECM 40	CFF-ECM 50	
D	mm	356	556	756	956	1156

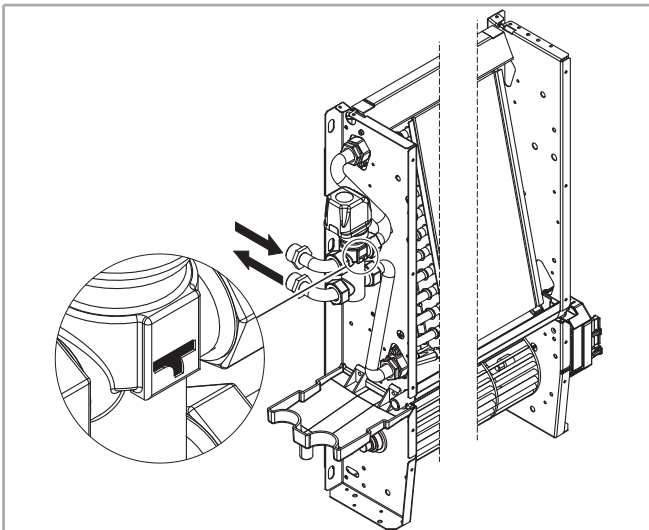

3 way valves pressure drop

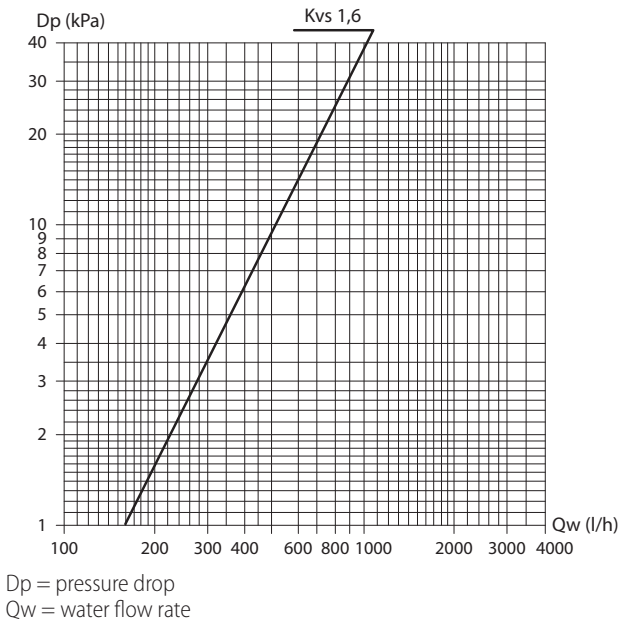

CONFIGURATIONS AND ELECTRONIC CONTROLS

Configuration

For this fan coil configuration, the 1-10 Vdc signal, which controls the inverter, must be supplied by a controller with the following signal specifications:

Fan Drive Signal

- 0 Vdc = Fan OFF
- >1 Vdc = Fan ON - Minimum speed
- 10 Vdc = Maximum speed

Blac-ECM Inverter board

0÷10 Vdc Circuit Input Impedance Value = 100 kOhm

Controls

All the CFF-ECM units can be supplied and managed with the following controls:

- **CB-E** control fitted on the unit (only version with casing, available mounted on site or supplied with separate packaging)
- **CB-Touch** control fitted on the unit with Bluetooth and Wi-Fi technology (only version with casing; available mounted on site or with separate packaging)
- **WM-AU** wall control (supplied with separate packaging)
- **T-MB2** wall control (supplied with separate packaging)

The **CB-Touch** control fitted on the unit allows moreover the control with the "**Sabiana WiFi**" and "**Sabiana BLE**" APP. This makes this fan coil unit the ideal solution for the air-conditioning of all residential ambients.

The **CB-Touch** control is equipped with a microprocessor with BLE/WiFi feature, that allows to control at distance or remotely all the units installed in your home.

With the BLE/WiFi technology it is possible to manage all the fan coil operation modes.

It is moreover possible to manage each single unit or to create some groups; a weekly program can be created by setting, for each day of the week, until four different operation modes.

Sabiana WiFi



Sabiana WiFi is the App for the control at a distance of your Sabiana system of climatization. Free and easy to use, it needs only a wireless network and a smartphone with internet connection. Using the "Cloud" it allows to manage, program and supervise the status of Your air conditioners wherever You are.

Sabiana BLE



Sabiana BLE is the new App for Android™ and iOS systems to set, manage and control Your

climatization system via Bluetooth Low Energy (BLE) transmission. Free and easy to configure and use, it needs only a smartphone with a Bluetooth connection (version 4.0 or later versions).

Our APP "**Sabiana WiFi**" and "**Sabiana BLE**" are compatible with iOS® e Android™ systems.

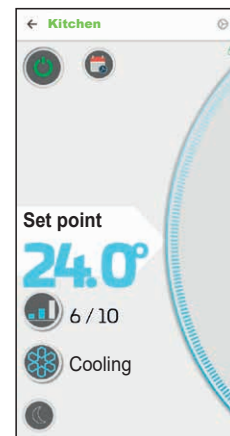
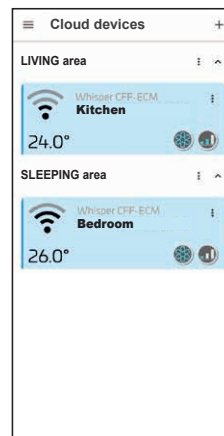

The **CB-E** and **CB-Touch** controls fitted on the unit, whose characteristics are described at p. 23, can be supplied either fitted on the unit or with separate packaging; those controls fitted on the unit that are separately bought can be used only with UP power unit to buy separately.

The **WM-AU** and **T-MB2** wall controls, whose characteristics are described from p. 23, are electronic controls that allow to manage one single unit or a group of units (only with the use of a power unit for each unit); the **WM-AU** and **T-MB2** controls can be bought only separately and can be used only with **UP-Touch** power units to buy separately.

The room temperature can be controlled through the Sabiana electronic room thermostats and are suitable when the user wants to set the fan speed.

CONTROLS

Controls fitted on the unit features

CB-E control fitted on the unit features



The CB-E control can be used only with a programmable thermostat not supplied by Sabiana. It allows to switch on and off the unit (Stand-by) and therefore to easily set the ventilation by progressively acting on the fan speed, leaving the temperature control to a centralised programmable thermostat or to a thermostat for the home automation system, which, in addition to enabling fan operation, will also control the opening and closing of the water valve on the connection pipe.

After a period of 3 minutes since the last action the brightness of the panel is reduced (SLEEPING mode) in order to increase the energy saving and the comfort during the night; only the symbol is shown on the display.

By pressing the same button twice, the brightness is restored.

CB-Touch control fitted on the unit features



The CB-Touch control allows to control and adjust the room temperature in a simple and intuitive way by means of a probe positioned in the lower part of the unit.

CB-Touch allows to select the desired operation mode, heat, cool or just ventilate the room, set a desired temperature set and adjust the fan operating speed according to your needs.

The maximum operation speed will be set to reach quickly the comfort temperature. Otherwise the minimum operation speed will be set when a noiseless operation is required, or the auto mode to optimise thermal and sound comfort.

With the low temperature cut-out thermostat (T3 sensor collocated between the coil fins; already wired for the units with fitted control, included together with the power unit and to wire for the versions without control) and according to the selected operation there will be as follows:

- winter cycle - the fan will only start operating if the water temperature is above 30 °C, thus preventing cold air from flowing out from the unit.
- summer cycle - the fan will only start operating if the water temperature is below 21 °C, thus preventing hot air from flowing out from the unit.

To improve comfort, it is also possible to select the night mode which minimises the fan speed and smartly changes the set temperature independently.

On the models with radiant panel during the winter cycle, the night mode activates the radiant panel and manages automatically the ventilation by optimizing it, until the fan is completely off and keeps the temperature steady only with the radiant panel; in this case the configured setpoint is not modified.

The control has a memory, so all settings will not be lost either in the event of switching off or power failure.

After a period of 3 minutes since the last action the brightness of the panel is reduced (SLEEPING mode) in order to increase the energy saving and the comfort during the night; only the symbol is shown on the display.

By pressing the same button twice, the brightness is restored.

The control is designed to be managed at distance with the smart features of one's own telephone by using the bluetooth wireless connection or wifi via APP downloadable from the Web.

IMPORTANT!: the device supports Wi-Fi networks (IEEE 802.11) of b, g and n type (Wi-Fi 4) with the following security methods :

- WEP
- WPA-PSK
- WPA2-PSK
- WPA2-enterprise

Controls fitted on the unit

CB-E control fitted on the unit

Model	Code	ID
10-20-30-40-50	9071060	CB-E



The control must always be connected with UP-ECO power unit (separately delivered).

(the power unit is already installed on the units with fitted control and must be ordered separately for the versions without control)

The main characteristics are:

- Set the unit ON or stand-by
- Set the fan speed
- Fan OFF and valve closing when the SETPOINT selected with the centralized thermostat (programmable thermostat) is reached.
- Button lock controller
- Regulation of LED brightness

Control power absorption: see the UP-ECO power unit

CB-Touch control fitted on the unit

Model	Code	ID
10-20-30-40-50	9071061	CB-Touch

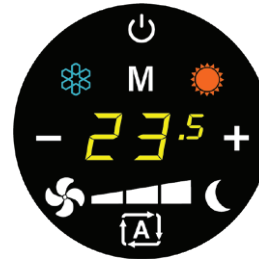

The control must always be connected with UP-Touch power unit (separately delivered).

(the power unit is already installed on the units with fitted control and must be ordered separately for the versions without control)

The main characteristics are:

- Set the unit ON or stand-by
- Operation mode (Summer/Winter/Ventilation)
- Set the fan speed
- Set the automatic fan speed
- Possibility to use the T1 sensor as return air probe (mounted on the power unit)
- Possibility to use the T3 sensor as low temperature cut-out thermostat (mounted on the power unit)
- It allows to use the T2 sensor as Change-over (mounted on the power unit).
- Night mode (with radiant panel activation in winter, on radiant models)
- Alarm messages
- OFFSET regulation
- Button lock controller
- Regulation of LED brightness
- To be controlled by APP Sabiana, both locally (BLE)[®], and locally or at a distance via Cloud (WiFi)

Control power absorption: see the UP-Touch power unit



Wall controls

WM-AU wall control

Model	Code	ID
10-20-30-40-50	9066632	WM-AU



The control must always be connected with UP-Touch power unit (separately delivered).

The main characteristics are:

- ON/OFF switch
- Manual/automatic 3 speed switch.
- Manual, automatic or centralized Summer/Winter switch.
- Summer/Winter/Fan/Auto mode switch.
- Electronic room thermostat for fan and water valves control (ON-OFF).
- Simultaneous thermostatic control of the valves and fan.
- Thermostatic control only with air probe fitted on the control.
- Possibility to use the T3 sensor as low temperature cut-out thermostat (mounted on the power unit)
- Possibility to use the T2 sensor as Change-over (mounted on the power unit).
- Energy saving function.
- Presence of a LED signal when the thermostat is on.

Control power absorption: see the UP-Touch power unit

Dimensions: 135x86x24 mm

T-MB2 wall control

Model	Code	ID
10-20-30-40-50	9066994E	T-MB2



The control must always be connected with UP-Touch power unit (separately delivered).

Control with TFT 2,4" coloured graphic display for wall installation, equipped with WiFi module and BLE for the management of the connected unit via Sabiana APP.

The main characteristics are:

- Management by keyboard, via connected supervision or via Sabiana APP
- Management of one single unit or of several units in Master/Slave mode
- ON/OFF switch
- Operation mode setting
- Setpoint configuration or setpoint variation by supervisory program (+/- 3°C of the set)
- Room temperature internal sensor, which can be defined as a priority compared to the return air sensor on the fan coil
- Fan speed switch
- Advanced daily/weekly ON/OFF programming with 3 pre-settable weekly programs
- Viewing and change of the operating mode parameters of the unit, alarm notification and information related to the unit
- Activation/deactivation of the room temperature display
- Radiant panel activation (for R versions)
- Firmware updating via Cloud
- Possibility to use the T1 sensor which allows the return air control (fitted on the power unit)
- Possibility to use the T3 sensor as water coil low temperature cut-out thermostat (fitted on the power unit)
- Possibility to use the T2 sensor which controls the summer/winter switch (Change-Over) (fitted on the power unit)

Control power absorption: see the UP-Touch power unit

Dimensions: 115x75x20 mm

WM-503-AC-EC wall control

Model	Code	ID
10-20-30-40-50	9066686	WM-503-AC-EC



The control must always be connected with UP-503-AC-EC power unit (separately delivered).

The WM-503-AC-EC control allows to regulate the room temperature in both, the heating and the cooling modes, it can control one or two valves and fan coil units with asynchronous motor or fan coil units with EC electronic motors.

The WM-503-AC-EC control is designed to be installed in a 503 wall box.

Easy to use, it is equipped with a large and efficient backlit LCD screen with 4 keys.

The kit lets the thermostat be suitable for all plaques on the market (28 types) and it is composed by: coloured covers (white, silver and anthracite), frames and adaptators.

The main characteristics are:

- Manual or automatic 3 speed motor control for asynchronous versions
- EC motor control with 0-10V signal for the ECM versions
- Power supply by UP-503-AC-EC by means of the two-core cable
- Input for return air/water/change over probe
- ON/OFF / SET Reduction / remote SUMMER-WINTER digital input
- User interface with LCD display with adjustable backlight and 4 keys
- 2 and 4 pipe fan coil units control
- Button lock controller

Control power absorption: see the UP-503-AC-EC power unit

Dimensions: 68x52.2x(wall protrusion=12) mm

Power units and probes

UP-ECO power unit

Model	Code	ID
10-20-30-40-50	9071064	UP-ECO



Power unit for CB-E control.

Power unit to be installed on the end unit (fan coil interface) and it is an interlock for the connection with an external programmable thermostat for the ON/OFF mode activation.

- It controls the motor/the fan and the fan coil valve.
- It is connected to the electric supply.
- It receives the required information to manage such parts from the remote control (programmable thermostat)

Power unit absorption: 11 VA (6 W)

UP-Touch power unit

Model	Code	ID
10-20-30-40-50	9071065	UP-Touch



Power unit for CB-Touch, WM-AU and T-MB2 controls

Power unit to be installed on the end unit (fan coil interface).

- It controls the motor/the fan and the fan coil valve.
- It is connected to the electric supply.
- It receives the information required to manage such parts from the CB-Touch control, from the WM-AU or from the T-MB2 controls
- Possibility to use the T1 sensor (included) for the T1 function which allows the return air control.
- Possibility to use the T3 sensor (included) for the T3 function as water coil low temperature cut-out thermostat (summer and winter operation)
- Possibility to use the T2 probe (included) for the T2 function which controls the summer/winter switch (change-over).
- It allows to control up to 10 units (1 master and 9 slaves).
- Max. network length: 100 meters.
- Max cable length between control and first connected power unit: 20 meters.

Power unit absorption: 11 VA (6 W)

UP-503-AC-EC power unit

Model	Code	ID
10-20-30-40-50	9066687	UP-503-AC-EC



Power unit for WM-503-AC-EC control.

The power unit must always be connected with the "Mounting kit for power unit" KIT 503-KNX code 9071076.

Power unit to be installed on the end unit (fan coil interface).

- It receives from the WM-503-AC-EC remote control the information required to control the valves and the motor.
- It allows to control up to 5 units (1 master and 4 slaves).
- Must be connected to the electric supply.
- Max. Network length: 100 meters.
- Max cable length between control and first connected power unit: 20 meters.

Power unit absorption: 2 VA

T2 probe

Model	Code	ID
10-20-30-40-50	9025310	T2



NTC probe type, to be placed on the water supply pipe upstream of the valves (not to be used with 2 way valves).

The T2 probe is to be used as Change-Over for 2 pipe systems, for the automatic switch of the operation mode. If water temperature is lower than 20 °C, cooling mode is set; on the other hand, if water temperature exceeds 30 °C, heating mode is set.

KNX Bus System

The KNX bus system is a building automation standard for controlling, managing and monitoring a wide range of products for:

- Heating, cooling, ventilation.
- Lighting.
- Alarm systems.
- Audio and video systems.
- Electricity and gas.

Since 2016, Sabiana is a certified member of the KNX association and the certified products can be added to this system in compliance with the tests carried out at KNX laboratories.



KNX devices

The Sabiana WM-KNX room thermostat controls and adjusts the temperature of a room or area in a building. In combination with one or several UP-KNX power units, the thermostat is able to control the operation of terminal units such as fan coils. The appliance consists of an

LCD display with adjustable backlight and a sensor for measuring the room temperature.

WM-KNX to be used only with UP-KNX (to combine to the 503-KNX KIT) and PL mounting plate, it is suitable for installation in a wall recessed box.

Note: all the controls are described in detail in the "Fan Coil Control Range literature".

Recessed thermostat WM-KNX



Power unit UP-KNX



WM-KNX with rectangular plate



WM-KNX with square plate



VERSION AND MAIN COMPONENTS

Range includes 4 air flow rates (from 40 to 400 m³/h) and 2 versions (standard with casing and for concealed installation), each one equipped with 2 row coil.

The standard versions with the casing are available in the following combinations:

- without control (CFF-MV)
- with control fitted on the unit (CFF-MV-CB)

The CFF range is perfect to meet all air-conditioning requirements of residential and work environments like offices, shops, restaurants and hotel rooms.

Outer casing

Made of galvanized steel and with plastic outer casing. The air diffuser, that is placed over the top of the unit, is of adjustable type. White RAL 9003.

Inner casing

Made of 1 mm galvanized steel, a rear panel and two lateral sides insulated with 3 mm polyolefin (PO) foam (B-s2-d0 EN 13501-1).

Filter

Polypropylene cellular fabric regenerating filter. The filter frame, made of synthetic material, is inserted into special plastic sliding guides fastened to the internal structure for easy insertion and removal of the filter.

Fan assembly

Made of plastic tangential fan with anti-vibration fins. The fan hub, dynamically and statically balanced, is directly secured onto the motor shaft.

Motor

The motor is for single phase supply and has 6 speeds, 3 of which are connected. It is fitted on anti-vibration self-lubricating mountings and with capacitor permanently fitted, internal thermal protection with automatic reset.

Protection IP 20, class B.

The electric power supply required for the machine is therefore single-phase with voltage of 230 V and frequency of 50 Hz.

Coil

It is manufactured from drawn copper tube and the aluminium fins are mechanically bonded onto the tube by an expansion process.

The coil has two Ø 1/2 inch BSP internal connections.

The coil has Ø 1/8" inch BSP air vent and drain.

The coil is not suitable for use in corrosive atmosphere or in environments where aluminium may be subject to corrosion.

The standard hydraulic connections are only on the left side facing the unit. It is not possible to connect hydraulically on the right side.

Valves

The versions without valves or with mounted valves are available for all sizes.

The available valves are:

- 2 way
- 3 way

The valves can be ordered separately and easily installed on the basic units without valves.

Condensate collection tray

Made of plastic (ABS UL94 HB) and fixed to the internal structure. The outside diameter of the condensate discharge pipe is Ø 15 mm.

VERSIONS

Standard version with casing - MV

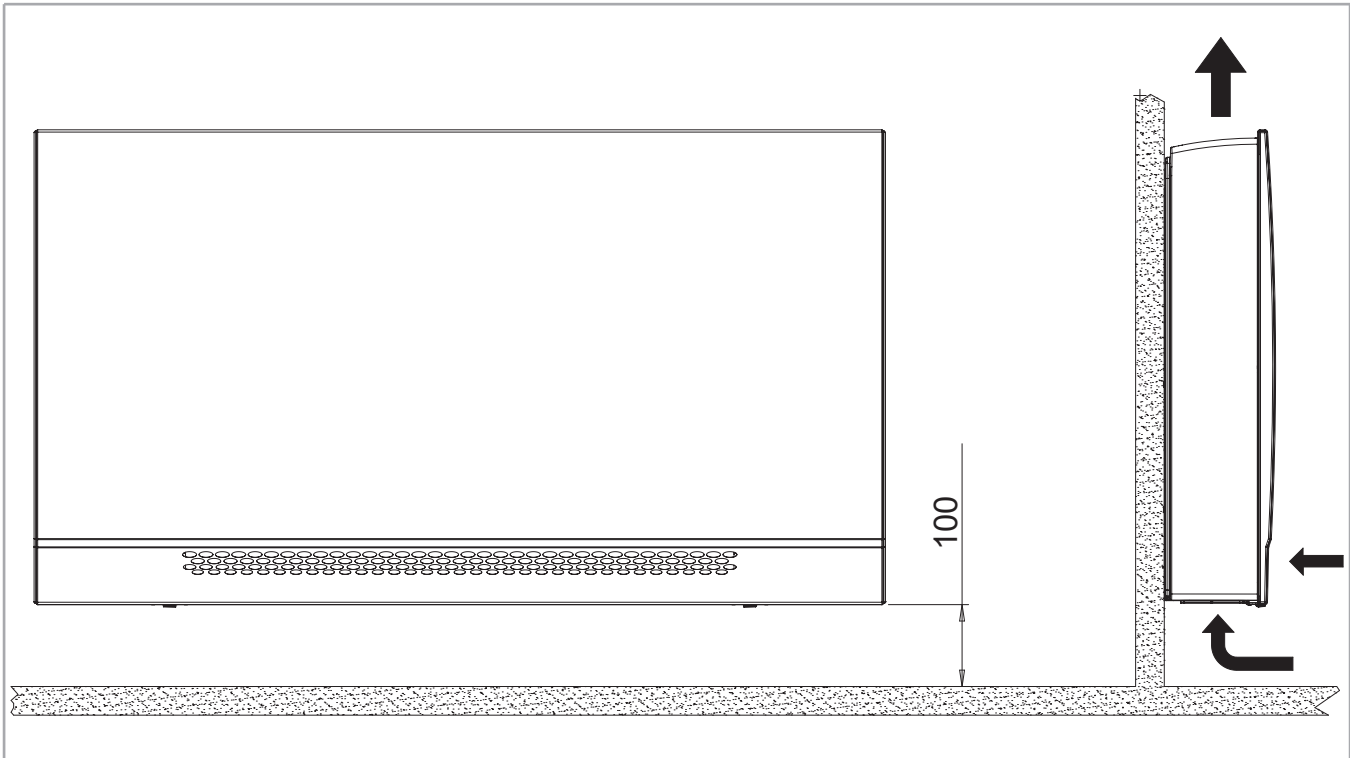

Version for concealed installation - IV

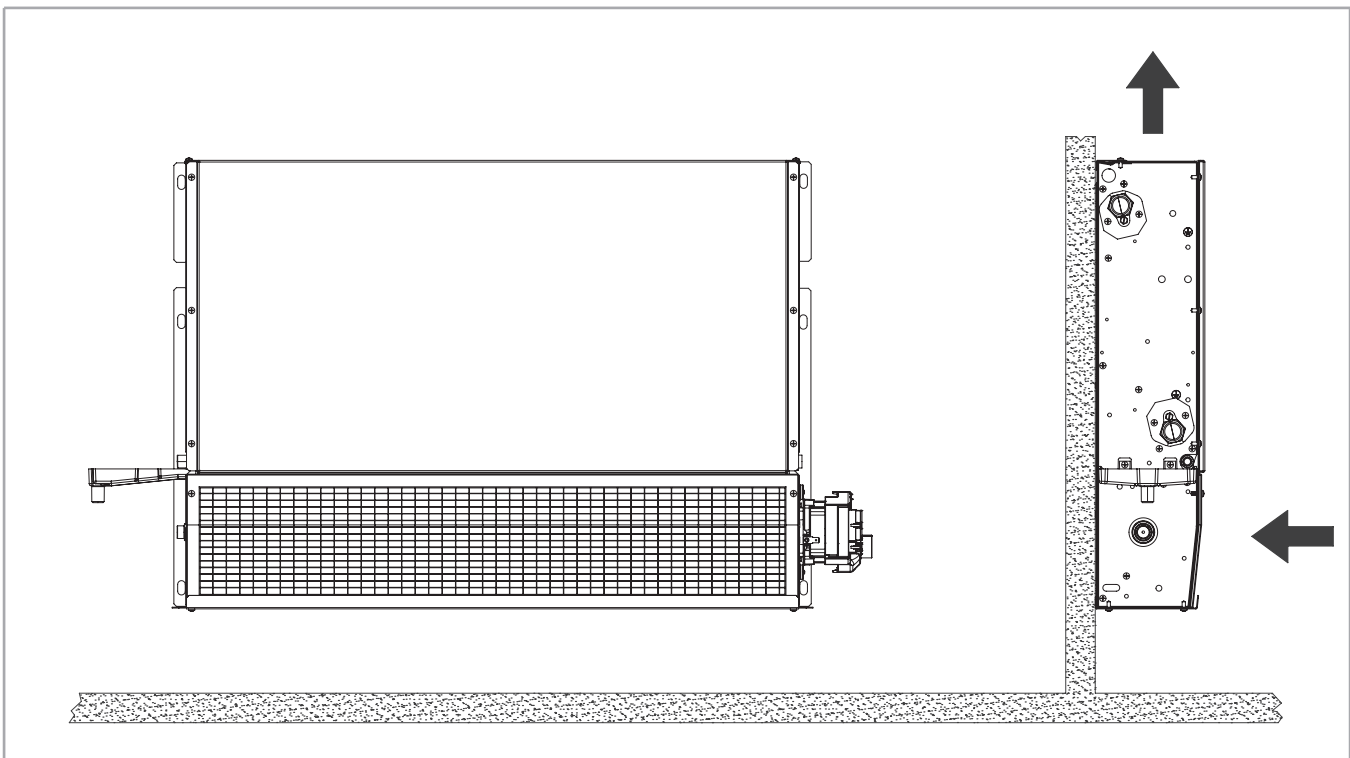

EUROVENT CERTIFICATION



The following standard rating conditions are used:

COOLING

Entering air temperature: + 27 °C d.b. + 19 °C w.b.
Water temperature: +7 °C E.W.T. +12 °C L.W.T.

HEATING

Entering air temperature: + 20 °C
Water temperature: +45 °C E.W.T. +40 °C L.W.T.

MODEL	Speed	CFF 10						CFF 20						CFF 30					
		1	2 MIN	3	4 MED	5	6 MAX	1	2 MIN	3	4 MED	5	6 MAX	1	2 MIN	3	4 MED	5	6 MAX
Eurovent certified performances.		-	E	-	E	-	E	-	E	-	E	-	E	-	E	-	E	-	E
Air flow	m ³ /h	58	75	102	126	135	165	110	151	170	210	225	280	150	180	200	290	320	378
Cooling total emission (E)	kW	0,33	0,41	0,54	0,62	0,70	0,80	0,63	0,85	1,00	1,15	1,25	1,45	0,82	1,14	1,30	1,74	1,92	2,18
Cooling sensible emission (E)	kW	0,24	0,30	0,41	0,48	0,55	0,64	0,46	0,63	0,75	0,88	0,96	1,14	0,59	0,82	0,93	1,27	1,41	1,62
Heating emission (E)	kW	0,45	0,51	0,64	0,76	0,80	0,94	0,87	1,05	1,13	1,34	1,42	1,69	1,24	1,34	1,43	1,96	2,13	2,44
Dp Cooling (E)	kPa	2,5	3,7	6,0	7,8	9,7	12,6	1,7	2,8	3,7	4,9	5,7	7,5	2,6	4,7	5,9	10,0	12,0	15,3
Dp Heating (E)	kPa	3,5	4,5	6,7	9,2	10,1	13,3	2,2	3,1	3,5	4,8	5,4	7,3	4,4	5,0	5,6	10,0	11,5	14,7
Motor power input (E)	W	8,0	10,0	12,0	15,0	17,0	31,0	9,0	12,0	13,0	18,0	20,0	34,0	11,0	14,0	15,0	20,0	22,0	39,0
Sound power (Lw) (E)	dB(A)	29	35	38	43	44	49	30	36	38	44	46	50	32	37	40	45	48	52
Sound pressure (Lp) ⁽¹⁾	dB(A)	20	26	29	34	35	40	21	27	29	35	37	41	23	28	31	36	39	43

MODEL	Speed	CFF 40					
		1	2 MIN	3	4 MED	5	6 MAX
Eurovent certified performances.		-	E	-	E	-	E
Air flow	m ³ /h	180	230	265	325	375	450
Cooling total emission (E)	kW	1,14	1,51	1,75	2,11	2,35	2,79
Cooling sensible emission (E)	kW	0,80	1,07	1,24	1,51	1,69	2,02
Heating emission (E)	kW	1,51	1,72	1,90	2,26	2,55	2,96
Dp Cooling (E)	kPa	5,7	9,6	12,5	17,5	21,3	29,2
Dp Heating (E)	kPa	7,7	9,7	11,6	15,9	19,8	25,9
Motor power input (E)	W	12,0	14,0	16,0	22,0	25,0	44,0
Sound power (Lw) (E)	dB(A)	28	34	35	42	44	50
Sound pressure (Lp) ⁽¹⁾	dB(A)	19	25	26	33	35	41

(E) Eurovent certified performance.

(1) The sound pressure levels are 9 dB (A) lower than the sound power levels, apply to the reverberant field of a 100 m³ room and a reverberation time of 0.5 sec.

MIN-MED-MAX = Speeds connected in the factory

COOLING EMISSION

Entering air temperature: 27 °C – R.H.: 50%

Model	Vn	Qv m ³ /h	WT: 7 / 12 °C				WT: 8 / 13 °C				WT: 10 / 15 °C				WT: 12 / 17 °C				
			Pc kW	Ps kW	Qw l/h	Dp(c) kPa	Pc kW	Ps kW	Qw l/h	Dp(c) kPa	Pc kW	Ps kW	Qw l/h	Dp(c) kPa	Pc kW	Ps kW	Qw l/h	Dp(c) kPa	
CFF 10	6	MAX	165	0,87	0,62	154	14,5	0,77	0,59	137	11,8	0,60	0,54	107	7,4	0,45	0,45	81	4,5
	5		135	0,76	0,54	133	11,1	0,68	0,51	119	9,1	0,52	0,47	92	5,7	0,39	0,39	70	3,4
	4	MED	126	0,67	0,47	117	8,9	0,60	0,45	105	7,3	0,46	0,41	82	4,6	0,35	0,35	62	2,8
	3		102	0,58	0,41	102	6,9	0,52	0,38	91	5,6	0,40	0,35	71	3,5	0,30	0,30	53	2,1
	2	MIN	75	0,44	0,30	77	4,2	0,39	0,28	69	3,4	0,30	0,26	54	2,1	0,23	0,23	40	1,3
	1		58	0,35	0,24	62	2,8	0,32	0,22	56	2,3	0,24	0,20	43	1,4	0,18	0,18	32	0,8
CFF 20	6	MAX	280	1,58	1,12	277	8,7	1,40	1,06	247	7,0	1,08	0,97	192	4,4	0,81	0,81	145	2,6
	5		225	1,36	0,95	237	6,5	1,21	0,90	212	5,3	0,93	0,81	164	3,3	0,70	0,70	123	2,0
	4	MED	210	1,25	0,87	218	5,6	1,12	0,82	195	4,6	0,86	0,75	151	2,9	0,64	0,64	113	1,7
	3		170	1,08	0,74	188	4,3	0,97	0,70	168	3,5	0,74	0,63	130	2,2	0,55	0,55	97	1,3
	2	MIN	151	0,91	0,63	159	3,2	0,82	0,59	143	2,6	0,63	0,54	110	1,6	0,47	0,47	83	1,0
	1		110	0,68	0,46	118	1,9	0,61	0,43	107	1,5	0,47	0,39	83	1,0	0,35	0,35	62	0,6
CFF 30	6	MAX	378	2,35	1,61	411	17,4	2,11	1,52	370	14,4	1,63	1,37	287	9,0	1,22	1,22	217	5,4
	5		320	2,06	1,40	358	13,6	1,85	1,32	323	11,2	1,43	1,19	250	7,0	1,07	1,07	188	4,2
	4	MED	290	1,87	1,27	324	11,4	1,69	1,19	293	9,5	1,30	1,07	227	5,9	0,97	0,97	171	3,5
	3		200	1,39	0,93	242	6,7	1,26	0,87	219	5,6	0,97	0,78	170	3,5	0,72	0,70	127	2,1
	2	MIN	180	1,22	0,81	212	5,3	1,10	0,77	192	4,4	0,86	0,68	149	2,8	0,64	0,62	112	1,6
	1		150	0,87	0,59	152	2,9	0,79	0,55	138	2,4	0,62	0,50	108	1,5	0,46	0,46	81	0,9
CFF 40	6	MAX	450	2,99	2,01	520	33,0	2,70	1,90	472	27,5	2,10	1,70	368	17,4	1,57	1,54	276	10,3
	5		375	2,52	1,69	437	24,0	2,28	1,59	396	20,1	1,78	1,42	309	12,7	1,33	1,29	232	7,5
	4	MED	325	2,25	1,50	391	19,7	2,05	1,42	355	16,5	1,59	1,26	277	10,5	1,19	1,14	208	6,2
	3		265	1,87	1,24	324	14,1	1,70	1,17	295	11,8	1,33	1,04	231	7,5	0,99	0,93	172	4,4
	2	MIN	230	1,62	1,07	280	10,8	1,47	1,01	255	9,1	1,15	0,89	200	5,8	0,85	0,81	149	3,4
	1		180	1,22	0,80	211	6,5	1,11	0,75	192	5,4	0,87	0,67	151	3,5	0,64	0,61	113	2,1

WT: Water temperature
Vn: Nominal speeds
Qv: Air flow
Pc: Cooling total emission
Ps: Cooling sensible emission
Qw: Water flow rate
Dp(c): Dp Cooling

Entering air temperature 26 °C – R.H.: 50%

Model	Vn	Qv m ³ /h	WT: 7 / 12 °C				WT: 8 / 13 °C				WT: 10 / 15 °C				WT: 12 / 17 °C				
			Pc kW	Ps kW	Qw l/h	Dp(c) kPa	Pc kW	Ps kW	Qw l/h	Dp(c) kPa	Pc kW	Ps kW	Qw l/h	Dp(c) kPa	Pc kW	Ps kW	Qw l/h	Dp(c) kPa	
CFF 10	6	MAX	165	0,77	0,59	137	11,7	0,68	0,57	121	9,4	0,52	0,52	94	5,8	0,39	0,39	71	3,5
	5		135	0,67	0,51	118	9,0	0,60	0,49	105	7,2	0,45	0,45	80	4,4	0,34	0,34	60	2,6
	4	MED	126	0,59	0,45	105	7,2	0,53	0,43	93	5,8	0,40	0,40	71	3,6	0,30	0,30	54	2,1
	3		102	0,52	0,38	91	5,6	0,46	0,37	80	4,5	0,35	0,33	61	2,7	0,26	0,26	46	1,6
	2	MIN	75	0,39	0,28	69	3,4	0,35	0,27	61	2,7	0,26	0,25	47	1,7	0,19	0,19	35	1,0
	1		58	0,31	0,22	55	2,3	0,28	0,21	49	1,8	0,21	0,19	37	1,1	0,15	0,15	28	0,7
CFF 20	6	MAX	280	1,40	1,06	246	7,0	1,23	1,01	218	5,6	0,94	0,92	167	3,4	0,70	0,70	126	2,0
	5		225	1,20	0,90	211	5,3	1,06	0,85	186	4,2	0,81	0,77	142	2,6	0,60	0,60	106	1,5
	4	MED	210	1,11	0,82	194	4,6	0,98	0,78	172	3,6	0,74	0,71	131	2,2	0,55	0,55	98	1,3
	3		170	0,96	0,70	167	3,5	0,85	0,66	148	2,8	0,64	0,60	112	1,7	0,47	0,47	83	1,0
	2	MIN	151	0,81	0,59	142	2,6	0,72	0,56	126	2,1	0,55	0,51	96	1,3	0,40	0,40	71	0,7
	1		110	0,61	0,43	106	1,5	0,54	0,41	94	1,2	0,41	0,37	72	0,7	0,30	0,30	53	0,4
CFF 30	6	MAX	378	2,10	1,52	368	14,3	1,86	1,45	326	11,5	1,42	1,31	250	7,0	1,05	1,05	187	4,1
	5		320	1,84	1,32	321	11,2	1,63	1,25	285	9,0	1,24	1,13	218	5,5	0,92	0,92	162	3,2
	4	MED	290	1,67	1,20	291	9,4	1,48	1,13	259	7,5	1,13	1,02	198	4,6	0,84	0,84	147	2,7
	3		200	1,25	0,88	218	5,5	1,11	0,82	194	4,5	0,84	0,74	147	2,7	0,62	0,62	109	1,6
	2	MIN	180	1,10	0,77	191	4,4	0,98	0,72	170	3,5	0,74	0,65	129	2,1	0,55	0,55	96	1,2
	1		150	0,78	0,55	137	2,4	0,70	0,52	122	2,0	0,54	0,48	94	1,2	0,40	0,40	71	0,7
CFF 40	6	MAX	450	2,68	1,90	468	27,3	2,39	1,80	417	22,1	1,82	1,62	320	13,5	1,35	1,35	238	7,9
	5		375	2,26	1,60	393	19,9	2,02	1,50	351	16,2	1,54	1,35	269	9,9	1,14	1,14	200	5,8
	4	MED	325	2,03	1,42	352	16,4	1,81	1,34	315	13,3	1,38	1,20	241	8,1	1,02	1,02	178	4,7
	3		265	1,68	1,17	292	11,7	1,51	1,10	262	9,6	1,15	0,98	200	5,8	0,84	0,84	148	3,3
	2	MIN	230	1,46	1,01	253	9,0	1,31	0,95	227	7,4	0,99	0,85	173	4,5	0,73	0,73	128	2,6
	1		180	1,10	0,76	190	5,4	0,98	0,71	171	4,4	0,75	0,64	131	2,7	0,55	0,55	97	1,6

WT: Water temperature
Vn: Nominal speeds
Qv: Air flow
Pc: Cooling total emission
Ps: Cooling sensible emission
Qw: Water flow rate
Dp(c): Dp Cooling

Entering air temperature: 25 °C – R.H.: 50%

Model	Vn	Qv m ³ /h	WT: 7 / 12 °C				WT: 8 / 13 °C				WT: 10 / 15 °C				WT: 12 / 17 °C				
			Pc kW	Ps kW	Qw l/h	Dp(c) kPa	Pc kW	Ps kW	Qw l/h	Dp(c) kPa	Pc kW	Ps kW	Qw l/h	Dp(c) kPa	Pc kW	Ps kW	Qw l/h	Dp(c) kPa	
CFF 10	6	MAX	165	0,38	0,38	69	3,3	0,59	0,54	107	7,4	0,45	0,45	82	4,6	0,38	0,38	69	3,3
	5		135	0,31	0,31	56	2,3	0,52	0,46	92	5,7	0,39	0,39	70	3,5	0,31	0,31	56	2,3
	4	MED	126	0,27	0,27	49	1,8	0,46	0,41	81	4,6	0,35	0,35	62	2,8	0,27	0,27	49	1,8
	3		102	0,22	0,22	40	1,2	0,40	0,35	70	3,5	0,30	0,30	53	2,1	0,22	0,22	40	1,2
	2	MIN	75	0,17	0,17	30	0,7	0,30	0,26	53	2,1	0,23	0,23	40	1,3	0,17	0,17	30	0,7
	1		58	0,13	0,13	24	0,5	0,24	0,20	43	1,4	0,18	0,18	32	0,9	0,13	0,13	24	0,5
CFF 20	6	MAX	280	0,66	0,66	119	1,8	1,08	0,97	192	4,4	0,81	0,81	146	2,7	0,66	0,66	119	1,8
	5		225	0,54	0,54	95	1,2	0,93	0,81	163	3,3	0,70	0,70	123	2,0	0,54	0,54	95	1,2
	4	MED	210	0,48	0,48	86	1,0	0,85	0,75	150	2,9	0,64	0,64	114	1,7	0,48	0,48	86	1,0
	3		170	0,40	0,40	72	0,7	0,74	0,63	129	2,2	0,55	0,55	97	1,3	0,40	0,40	72	0,7
	2	MIN	151	0,35	0,35	62	0,6	0,63	0,53	110	1,6	0,47	0,47	83	1,0	0,35	0,35	62	0,6
	1		110	0,26	0,26	46	0,3	0,47	0,39	82	1,0	0,35	0,35	62	0,6	0,26	0,26	46	0,3
CFF 30	6	MAX	378	0,90	0,90	162	3,2	1,63	1,37	286	9,1	1,23	1,23	217	5,5	0,90	0,90	162	3,2
	5		320	0,79	0,79	140	2,4	1,43	1,19	250	7,1	1,08	1,08	189	4,2	0,79	0,79	140	2,4
	4	MED	290	0,72	0,72	127	2,1	1,30	1,07	226	5,9	0,98	0,97	171	3,6	0,72	0,72	127	2,1
	3		200	0,53	0,53	93	1,2	0,97	0,78	169	3,5	0,72	0,70	127	2,1	0,53	0,53	93	1,2
	2	MIN	180	0,47	0,47	82	0,9	0,85	0,68	149	2,8	0,64	0,62	112	1,6	0,47	0,47	82	0,9
	1		150	0,34	0,34	61	0,5	0,61	0,50	107	1,5	0,46	0,46	82	0,9	0,34	0,34	61	0,5
CFF 40	6	MAX	450	1,16	1,16	205	6,0	2,09	1,70	366	17,4	1,57	1,53	277	10,5	1,16	1,16	205	6,0
	5		375	0,98	0,98	172	4,4	1,77	1,43	308	12,7	1,33	1,28	233	7,6	0,98	0,98	172	4,4
	4	MED	325	0,87	0,87	153	3,6	1,58	1,26	276	10,5	1,19	1,13	208	6,2	0,87	0,87	153	3,6
	3		265	0,72	0,72	127	2,5	1,32	1,04	229	7,5	0,99	0,93	173	4,5	0,72	0,72	127	2,5
	2	MIN	230	0,63	0,63	110	2,0	1,14	0,90	199	5,8	0,86	0,80	150	3,4	0,63	0,63	110	2,0
	1		180	0,47	0,47	83	1,2	0,86	0,67	150	3,5	0,65	0,61	113	2,1	0,47	0,47	83	1,2

- WT:** Water temperature
- Vn:** Nominal speeds
- Qv:** Air flow
- Pc:** Cooling total emission
- Ps:** Cooling sensible emission
- Qw:** Water flow rate
- Dp(c):** Dp Cooling

HEATING EMISSION

Entering air temperature: 18 °C

Model	Vn	Qv m ³ /h	WT: 70 / 60 °C			WT: 60 / 50 °C			WT: 50 / 40 °C			WT: 50 / 45 °C			WT: 45 / 40 °C			
			Ph kW	Qw l/h	Dp(h) kPa	Ph kW	Qw l/h	Dp(h) kPa	Ph kW	Qw l/h	Dp(h) kPa	Ph kW	Qw l/h	Dp(h) kPa	Ph kW	Qw l/h	Dp(h) kPa	
CFF 10	6	MAX	165	1,99	172	13,7	1,56	134	9,1	1,12	96	5,2	1,25	214	21,8	1,03	177	15,7
	5		135	1,71	147	10,4	1,34	115	6,9	0,96	83	4,0	1,06	183	16,4	0,88	152	11,9
	4	MED	126	1,62	139	9,4	1,27	109	6,3	0,91	78	3,6	1,01	173	14,9	0,83	143	10,8
	3		102	1,36	117	6,9	1,07	92	4,6	0,77	66	2,7	0,85	146	10,9	0,70	121	7,9
	2	MIN	75	1,08	93	4,6	0,85	73	3,1	0,62	53	1,8	0,68	116	7,2	0,56	96	5,3
	1		58	0,94	81	3,6	0,74	64	2,4	0,54	47	1,4	0,59	101	5,6	0,49	84	4,1
CFF 20	6	MAX	280	3,59	309	7,5	2,81	242	5,0	2,02	174	2,9	2,24	385	11,9	1,85	319	8,6
	5		225	3,02	259	5,5	2,36	203	3,7	1,71	147	2,1	1,88	323	8,7	1,56	268	6,3
	4	MED	210	2,85	245	5,0	2,24	192	3,3	1,62	139	1,9	1,78	305	7,9	1,47	253	5,7
	3		170	2,39	206	3,6	1,88	162	2,4	1,36	117	1,4	1,49	256	5,7	1,24	213	4,2
	2	MIN	151	2,22	191	3,2	1,75	150	2,1	1,27	109	1,2	1,38	238	5,0	1,15	197	3,6
	1		110	1,84	158	2,3	1,45	124	1,5	1,05	91	0,9	1,14	196	3,5	0,95	163	2,6
CFF 30	6	MAX	378	5,16	443	15,1	4,06	349	10,1	2,95	254	5,9	3,21	552	23,8	2,67	459	17,3
	5		320	4,50	387	11,8	3,54	305	7,9	2,58	222	4,7	2,80	481	18,5	2,33	400	13,6
	4	MED	290	4,14	356	10,1	3,27	281	6,9	2,39	205	4,0	2,58	443	16,0	2,14	369	11,7
	3		200	3,02	259	5,7	2,39	205	3,9	1,75	151	2,3	1,87	322	9,0	1,56	269	6,6
	2	MIN	180	2,82	243	5,1	2,24	192	3,5	1,64	141	2,1	1,75	302	8,0	1,46	251	5,9
	1		150	2,61	225	4,4	2,07	178	3,0	1,52	131	1,8	1,62	279	6,9	1,35	232	5,1
CFF 40	6	MAX	450	6,26	538	26,4	4,94	425	17,9	3,62	311	10,5	3,90	670	41,6	3,24	558	30,5
	5		375	5,38	462	20,1	4,25	366	13,6	3,12	268	8,1	3,35	576	31,7	2,79	479	23,2
	4	MED	325	4,77	410	16,2	3,77	324	11,0	2,77	238	6,5	2,96	509	25,4	2,47	425	18,7
	3		265	4,00	344	11,8	3,17	273	8,0	2,34	201	4,8	2,48	427	18,5	2,07	356	13,6
	2	MIN	230	3,63	312	9,9	2,88	248	6,7	2,12	183	4,0	2,25	387	15,5	1,88	323	11,4
	1		180	3,17	273	7,8	2,52	217	5,3	1,86	160	3,2	1,97	338	12,2	1,64	283	9,0

WT: Water temperature
Vn: Nominal speeds
Qv: Air flow
Ph: Heating emission
Qw: Water flow rate
Dp(h): Dp Heating

Entering air temperature: 20 °C

Model	Vn	Qv m³/h	WT: 70 / 60 °C			WT: 60 / 50 °C			WT: 50 / 40 °C			WT: 50 / 45 °C			WT: 45 / 40 °C			
			Ph kW	Qw l/h	Dp(h) kPa	Ph kW	Qw l/h	Dp(h) kPa	Ph kW	Qw l/h	Dp(h) kPa	Ph kW	Qw l/h	Dp(h) kPa	Ph kW	Qw l/h	Dp(h) kPa	
CFF 10	6	MAX	165	1,90	163	12,6	1,46	126	8,1	1,03	88	4,5	1,15	199	19,0	0,94	162	13,3
	5		135	1,62	140	9,5	1,26	108	6,2	0,88	76	3,4	0,99	170	14,3	0,80	138	10,1
	4	MED	126	1,54	132	8,6	1,19	102	5,6	0,84	72	3,1	0,93	161	13,0	0,76	131	9,2
	3		102	1,30	112	6,3	1,01	87	4,1	0,71	61	2,3	0,79	136	9,6	0,64	111	6,7
	2	MIN	75	1,03	89	4,2	0,80	69	2,8	0,57	49	1,5	0,63	108	6,3	0,51	88	4,5
	1		58	0,90	77	3,3	0,70	60	2,2	0,50	43	1,2	0,55	94	4,9	0,45	77	3,5
CFF 20	6	MAX	280	3,42	294	6,9	2,64	227	4,5	1,86	160	2,5	2,08	357	10,4	1,69	291	7,3
	5		225	2,87	247	5,0	2,22	191	3,3	1,57	135	1,8	1,74	300	7,6	1,42	244	5,4
	4	MED	210	2,71	233	4,6	2,10	181	3,0	1,49	128	1,7	1,65	283	6,9	1,34	231	4,8
	3		170	2,28	196	3,3	1,77	152	2,2	1,26	108	1,2	1,38	238	5,0	1,13	194	3,5
	2	MIN	151	2,12	182	2,9	1,64	141	1,9	1,17	100	1,1	1,28	221	4,4	1,05	180	3,1
	1		110	1,75	150	2,1	1,36	117	1,4	0,97	84	0,8	1,06	182	3,1	0,87	149	2,2
CFF 30	6	MAX	378	4,91	422	13,8	3,82	329	9,1	2,72	234	5,1	2,98	512	20,8	2,44	419	14,7
	5		320	4,28	368	10,8	3,34	287	7,1	2,38	205	4,0	2,60	446	16,2	2,13	366	11,5
	4	MED	290	3,95	339	9,3	3,08	265	6,2	2,20	189	3,5	2,39	411	14,0	1,96	337	10,0
	3		200	2,87	247	5,3	2,25	193	3,5	1,62	139	2,0	1,74	299	7,9	1,43	246	5,6
	2	MIN	180	2,69	232	4,7	2,11	181	3,1	1,52	130	1,8	1,63	280	7,0	1,34	230	5,0
	1		150	2,49	214	4,1	1,95	168	2,7	1,41	121	1,6	1,51	259	6,1	1,24	213	4,4
CFF 40	6	MAX	450	5,97	513	24,2	4,65	400	16,0	3,34	287	9,1	3,61	622	36,4	2,96	510	25,9
	5		375	5,13	441	18,4	4,01	345	12,2	2,88	247	7,0	3,10	534	27,7	2,55	439	19,8
	4	MED	325	4,54	391	14,8	3,55	306	9,9	2,56	220	5,7	2,75	473	22,2	2,26	389	15,9
	3		265	3,81	328	10,8	2,99	257	7,2	2,16	185	4,2	2,31	397	16,2	1,90	326	11,6
	2	MIN	230	3,46	297	9,1	2,71	233	6,1	1,96	169	3,5	2,09	360	13,6	1,72	296	9,7
	1		180	3,02	260	7,1	2,37	204	4,8	1,72	148	2,8	1,83	314	10,7	1,51	259	7,7

WT: Water temperature
Vn: Nominal speeds
Qv: Air flow
Ph: Heating emission
Qw: Water flow rate
Dp(h): Dp Heating

Entering air temperature: 22 °C

Model	Vn	Qv m ³ /h	WT: 70 / 60 °C			WT: 60 / 50 °C			WT: 50 / 40 °C			WT: 50 / 45 °C			WT: 45 / 40 °C			
			Ph kW	Qw l/h	Dp(h) kPa	Ph kW	Qw l/h	Dp(h) kPa	Ph kW	Qw l/h	Dp(h) kPa	Ph kW	Qw l/h	Dp(h) kPa	Ph kW	Qw l/h	Dp(h) kPa	
CFF 10	6	MAX	165	1,80	155	11,5	1,37	118	7,2	0,94	80	3,8	1,06	183	16,4	0,85	146	11,1
	5		135	1,54	133	8,7	1,18	101	5,5	0,81	69	2,9	0,91	156	12,4	0,73	125	8,4
	4	MED	126	1,46	126	7,9	1,11	96	5,0	0,76	66	2,6	0,86	148	11,2	0,69	119	7,6
	3		102	1,23	106	5,8	0,94	81	3,7	0,65	56	2,0	0,73	125	8,3	0,58	100	5,6
	2	MIN	75	0,98	84	3,8	0,75	65	2,5	0,52	45	1,3	0,58	99	5,5	0,46	80	3,8
	1		58	0,86	74	3,0	0,66	56	1,9	0,46	39	1,0	0,50	87	4,3	0,40	70	2,9
CFF 20	6	MAX	280	3,25	280	6,3	2,48	213	4,0	1,69	146	2,1	1,91	329	9,0	1,53	263	6,1
	5		225	2,73	235	4,6	2,08	179	2,9	1,43	123	1,5	1,61	276	6,6	1,29	221	4,5
	4	MED	210	2,58	222	4,2	1,97	170	2,7	1,36	117	1,4	1,52	261	5,9	1,22	209	4,1
	3		170	2,17	186	3,0	1,66	143	1,9	1,15	99	1,0	1,28	219	4,3	1,02	176	3,0
	2	MIN	151	2,01	173	2,7	1,54	133	1,7	1,07	92	0,9	1,18	203	3,8	0,95	164	2,6
	1		110	1,66	143	1,9	1,28	110	1,2	0,89	76	0,7	0,98	168	2,7	0,79	135	1,8
CFF 30	6	MAX	378	4,67	402	12,6	3,59	308	8,1	2,49	214	4,4	2,75	473	18,0	2,21	380	12,4
	5		320	4,08	350	9,9	3,13	269	6,4	2,18	188	3,4	2,40	412	14,0	1,93	332	9,7
	4	MED	290	3,75	323	8,5	2,89	249	5,5	2,01	173	3,0	2,21	380	12,1	1,78	306	8,4
	3		200	2,74	235	4,8	2,11	182	3,1	1,48	128	1,7	1,61	276	6,8	1,30	223	4,7
	2	MIN	180	2,56	220	4,3	1,98	170	2,8	1,39	120	1,5	1,50	259	6,1	1,22	209	4,2
	1		150	2,37	204	3,7	1,83	158	2,4	1,29	111	1,3	1,39	239	5,3	1,12	193	3,7
CFF 40	6	MAX	450	5,67	488	22,1	4,37	376	14,3	3,06	263	7,8	3,34	574	31,5	2,69	463	21,8
	5		375	4,88	419	16,8	3,76	324	10,9	2,64	227	6,0	2,87	493	24,0	2,32	398	16,6
	4	MED	325	4,32	372	13,6	3,34	287	8,8	2,35	202	4,8	2,54	437	19,3	2,05	353	13,4
	3		265	3,63	312	9,9	2,81	241	6,5	1,98	170	3,6	2,13	366	14,0	1,72	297	9,8
	2	MIN	230	3,29	283	8,3	2,55	219	5,4	1,80	155	3,0	1,93	332	11,8	1,56	269	8,2
	1		180	2,88	247	6,5	2,23	192	4,3	1,58	136	2,4	1,69	290	9,2	1,37	235	6,4

WT: Water temperature
Vn: Nominal speeds
Qv: Air flow
Ph: Heating emission
Qw: Water flow rate
Dp(h): Dp Heating

WATER SIDE PRESSURE DROP

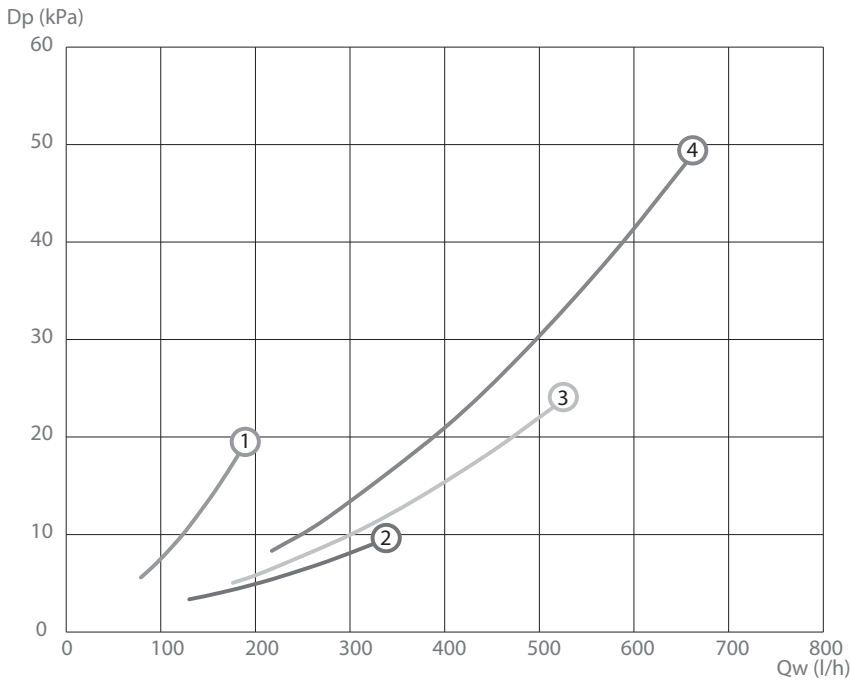

Dp = pressure drop
 Qw = water flow rate
 1 = CFF 10
 2 = CFF 20
 3 = CFF 30
 4 = CFF 40

Pressure drop for mean water temperature of **10 °C**; for different temperatures multiply the pressure drop figure by the **K** correction factors in the table.

	Mean water temperature (°C)						
	20	30	40	50	60	70	80
K correction factor	0,94	0,90	0,86	0,82	0,78	0,74	0,70

OPERATION LIMITS

Description	UoM	Value	
Water flow	Coil maximum working pressure	bars	16
		kPa	1600
	Lowest water inlet temperature	°C	6
	Highest water inlet temperature	°C	85
Power supply	Single-phase rated operating voltage	V/Hz	230/50

Coils water flow limits

2 row coil

Model		CFF 10	CFF 20	CFF 30	CFF 40
Water flow rate Min.	l/h	40	80		120
Water flow rate Max.	l/h	200	350	500	600

Motor max. absorption

Model		CFF 10	CFF 20	CFF 30	CFF 40
Motor absorption	W	31,0	34,0	39,0	44,0

DIMENSIONS

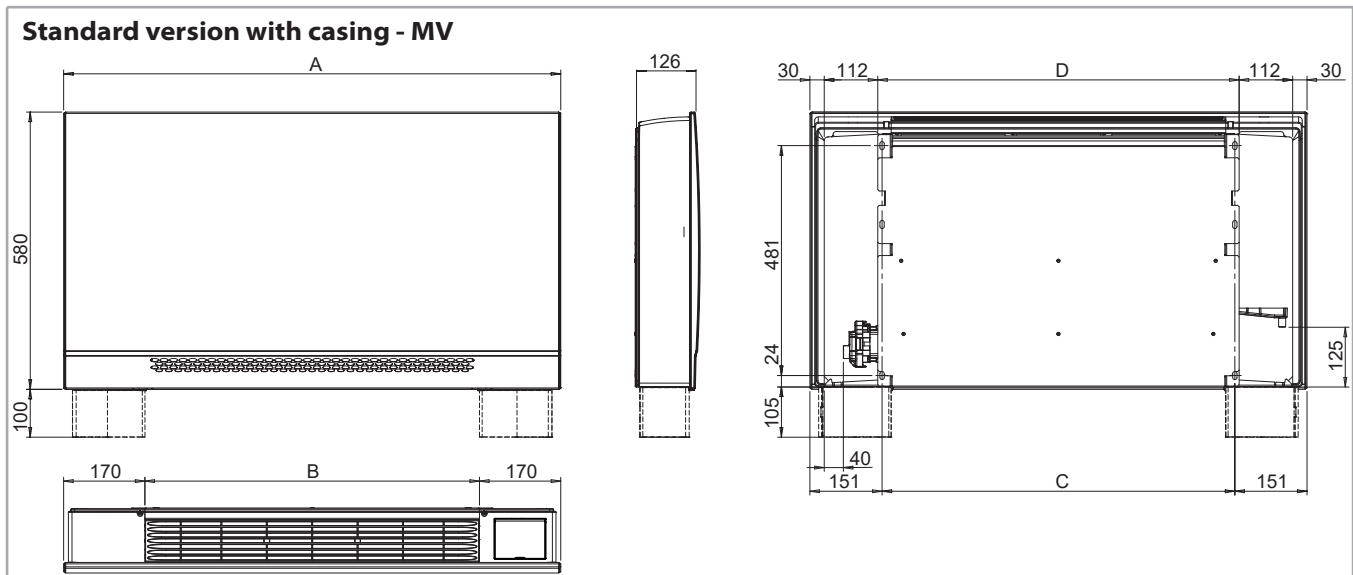

Model		CFF 10	CFF 20	CFF 30	CFF 40
A	mm	640	840	1040	1240
B	mm	300	500	700	900
C	mm	338	538	738	938
D	mm	356	556	756	956

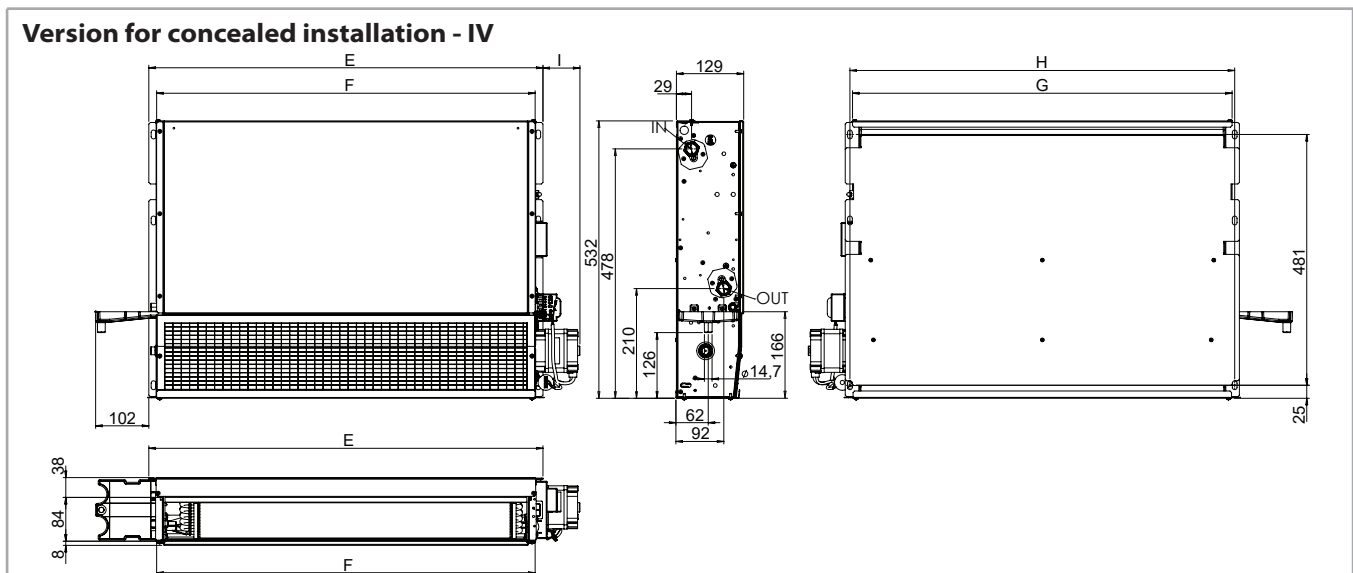

Model		10	20	30	40
E	mm	356	556	756	956
F	mm	326	526	726	926
G	mm	328	528	728	928
H	mm	338	538	738	938
I	mm	61	71	71	71

Hydraulic connections

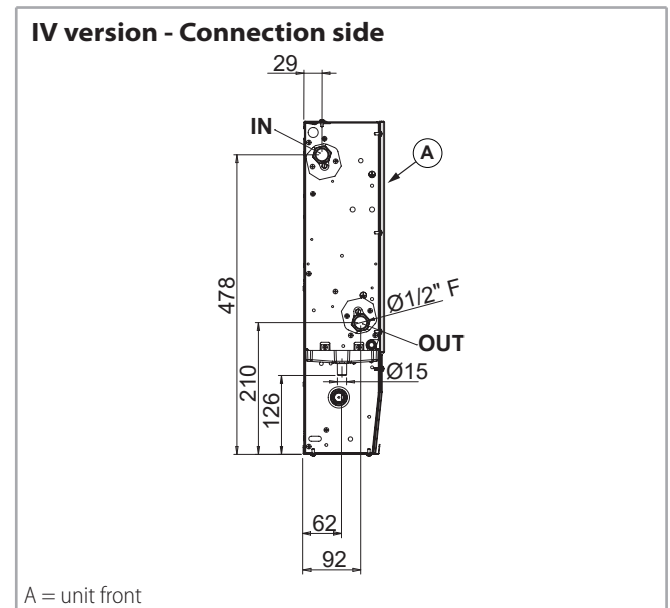
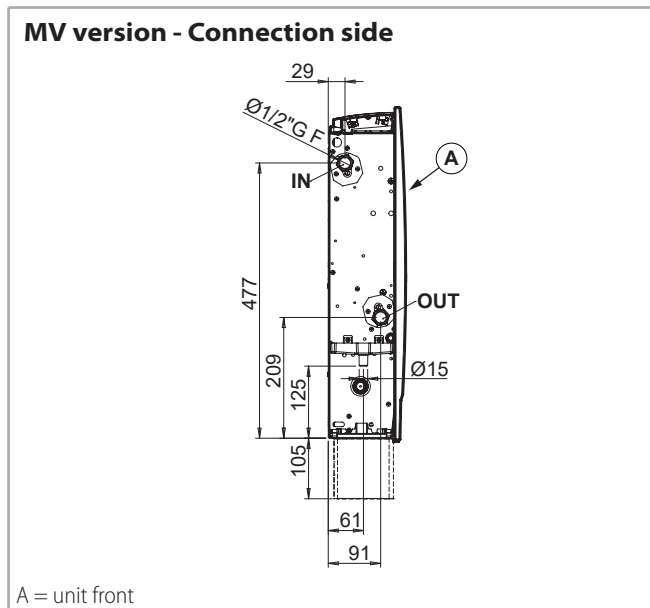

Packed unit

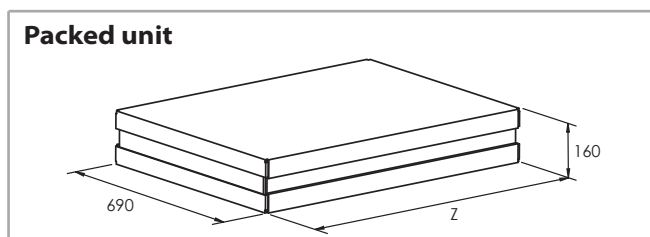

Model	CFF 10	CFF 20	CFF 30	CFF 40	
Z	mm	720	920	1120	1320

Weight

The table of the weight is related to the standard versions with casing in the basic configuration with control

and without valves; the weights can change for those units completed with control and/or valve.

Standard version with MV casing

Model		CFF-MV 10	CFF-MV 20	CFF-MV 30	CFF-MV 40
Weight with packaging	kg	12,5	16,0	19,5	22,5
Weight without packaging	kg	11,0	14,5	17,5	21,0

IV version for concealed installation

Model		10	20	30	40
Weight with packaging	kg	10,1	13,6	17,3	20,9
Weight without packaging	kg	8,5	11,7	15,1	18,5

Water content

Model		CFF 10	CFF 20	CFF 30	CFF 40
Water content	l	0,4	0,7	1,1	1,4

VALVES

The CFF units are available either in the versions with mounted valves and in the versions without valves. The features and the installation dimensions of the valves are shown as follows and are valid either for the

versions with mounted valves and for the versions with valves installed on site.

2 way valve

2 way valve ON-OFF 230 V

Model	Kvs m ³ /h	Dp max ⁽¹⁾ kPa	Valve connections (male) Ø	NOT FITTED	
				Code	ID
10-20-30-40	1,7	50	1/2"	9071090W	V2-F

(1) Maximum pressure difference for valve to close

Connection side and back sight

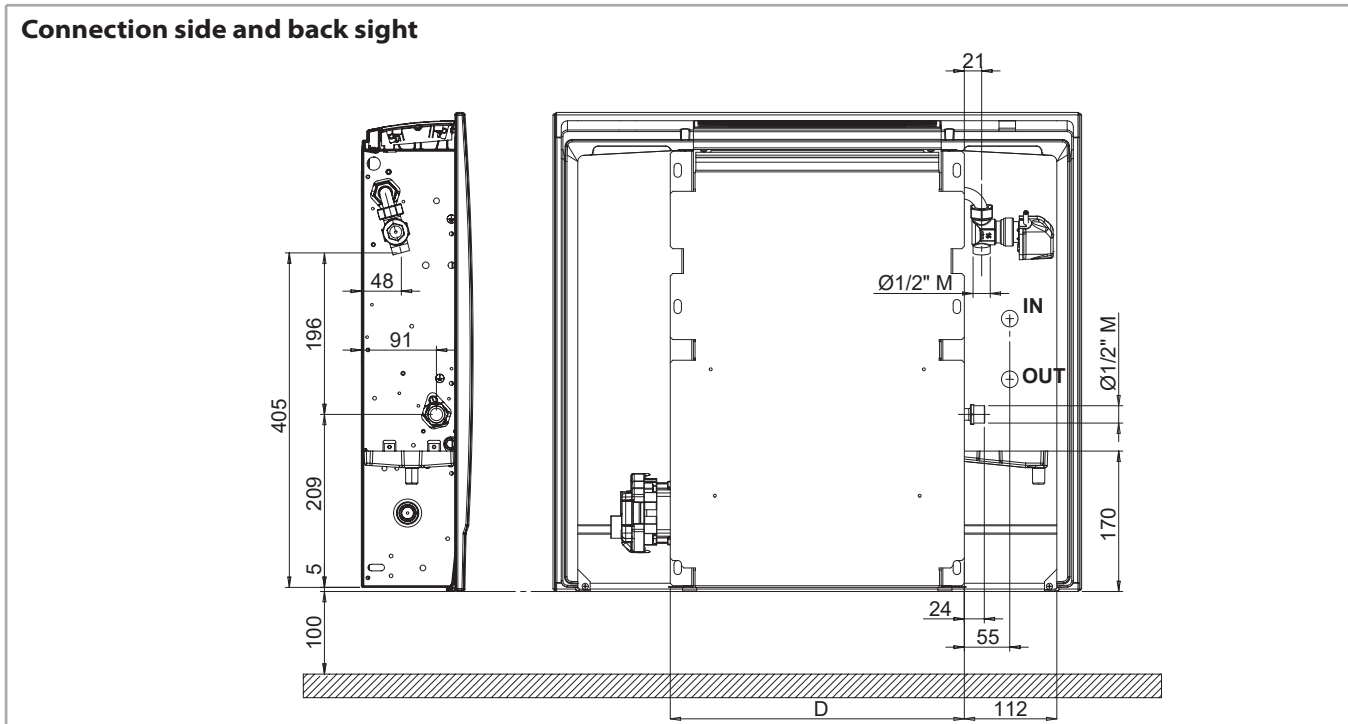

Model		CFF 10	CFF 20	CFF 30	CFF 40
D	mm	356	556	756	956

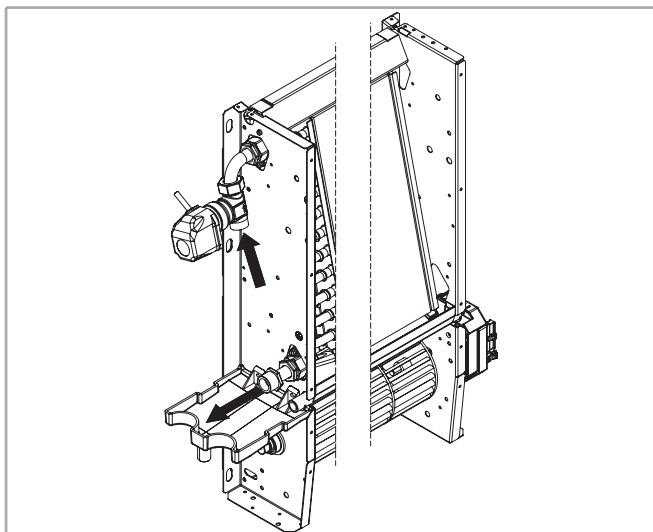

2 way valves pressure drop

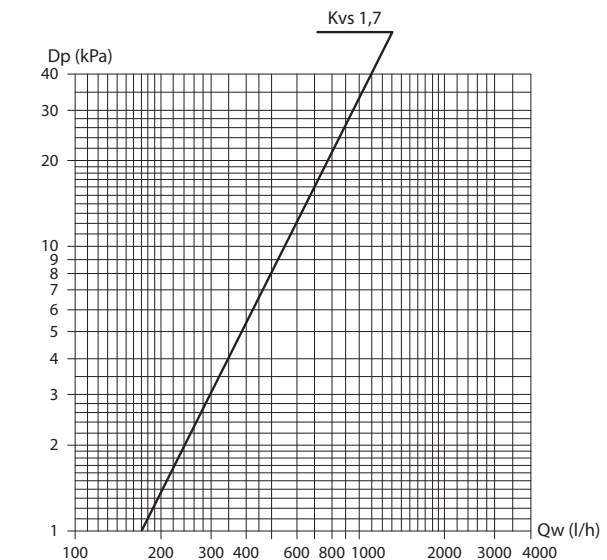

Dp = pressure drop
Qw = water flow rate

3 way valves

3 way water valve ON-OFF 230 V and mounting kit.

Model	Kvs m ³ /h	Dp max ⁽¹⁾ kPa	Pipe kit connection (male) Ø	NOT FITTED	
				Code	ID
10-20-30-40	1,6	50	1/2"	9071091W	V3-F

(1) Maximum pressure difference for valve to close

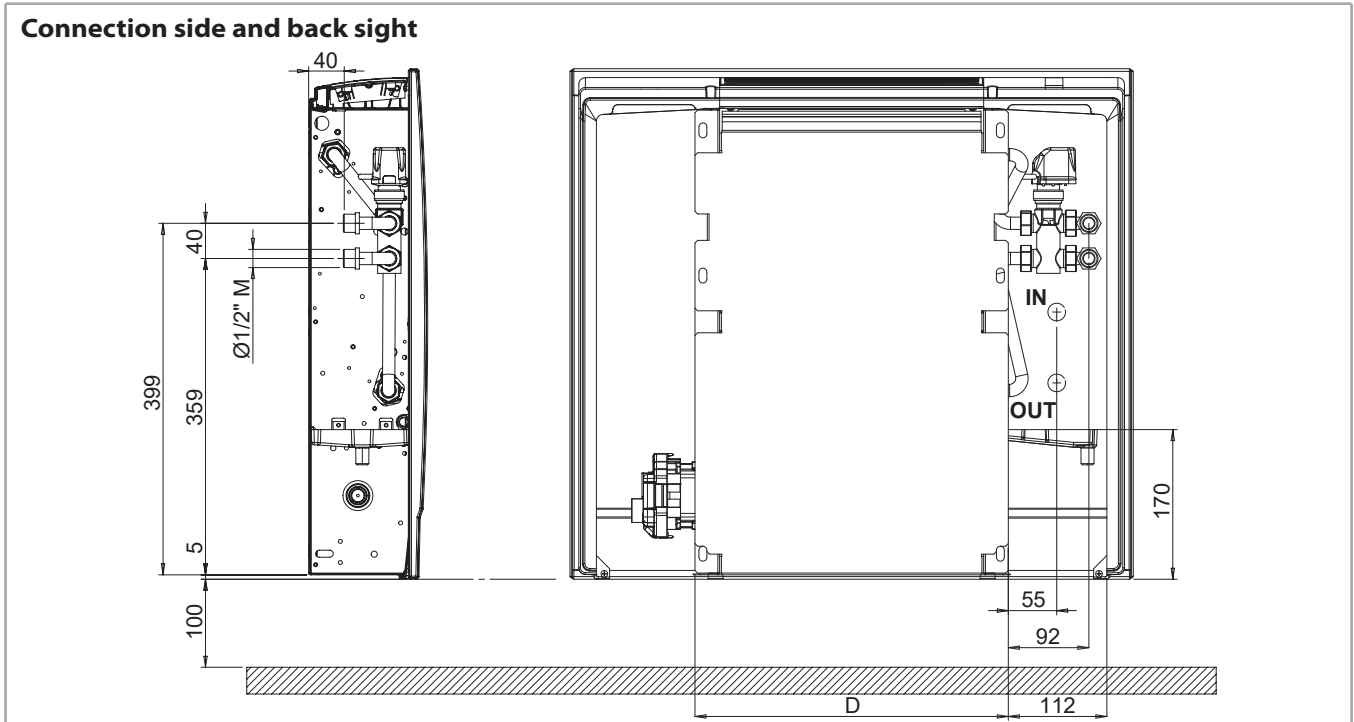

Model	CFF 10	CFF 20	CFF 30	CFF 40	
D	mm	356	556	756	956

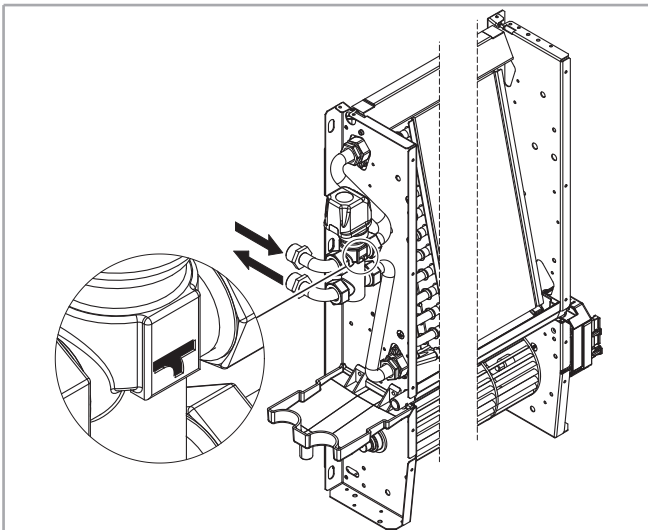

3 way valves pressure drop

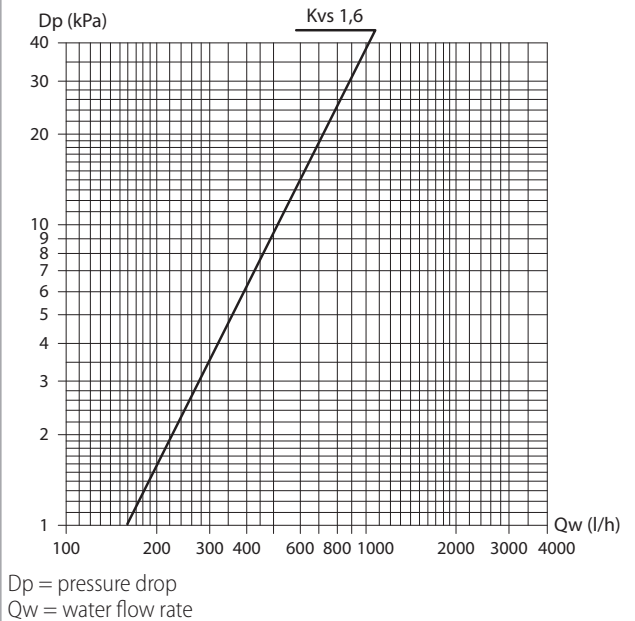

CONTROLS

Control fitted on the unit

All the CFF-MV-CB units are equipped with **CB-T-CFF** electronic control fitted on board, that allows the management of one single unit.



Control panel with electronic room thermostat for 2-4 tube installations:

- manual 3 speed switch
- thermostatic control of the fan and of the valve.
- manual Summer/Winter switch.
- TMM low temperature cut-out thermostat (optional).

Wall controls

WM-3V

Model	Code	ID
1-2-3-4	9066642	WM-3V



- Manual 3 speed switch, without thermostatic control.
- It does not control the valves.
- It allows to control the low temperature cut-out thermostat TMM

Dimensions: 75x75x30 mm

WM-T

Model	Code	ID
1-2-3-4	9066630	WM-T



- Manual 3 speed switch.
- Manual Summer/Winter switch.
- Electronic room thermostat for fan control (ON-OFF).
- Electronic room thermostat for valve control (ON-OFF).
- It allows to control the low temperature cut-out thermostat TMM.
- Presence of a LED signal when the thermostat is on.

Control power absorption: 0,25 VA

Dimensions: 135x86x31 mm

Accessories for controls

TMM low temperature cut-out thermostat (optional)

Code	ID
9053048	TMM



To be installed in contact with the hot water circuit.

For units working on heating only.

It stops the fan when the water temperature is lower than 30 °C and it starts the fan when is higher than 38 °C.

Receiving board for centralized control of more units for WM-T

Code	ID
9071068	SEL-CR-CF



- Speed switch (Slave).
- It allows to control up to 8 units with only one centralized wall control (1 speed switch for each unit).

ACCESSORIES

Feet

Model	Code	ID
10-20-30-40-50	9071074	PAP-F

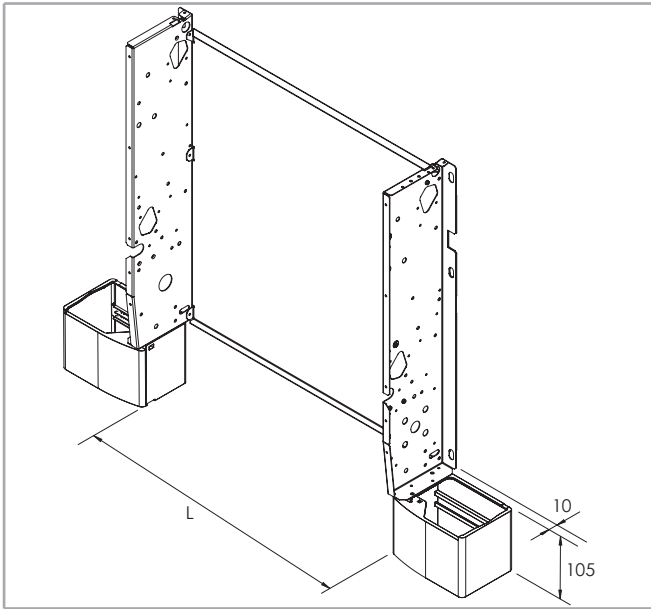

Model		10	20	30	40	50
D	mm	300	500	700	900	1100

Horizontal condensate collection tray kit for IV version

The concealed standard installation can be installed horizontally by using the optional horizontal condensate tray kit.

Model	Code	ID
10	9071271	BSI-CF 10
20	9071272	BSI-CF 20
30	9071273	BSI-CF 30
40	9071274	BSI-CF 40
50	9071275	BSI-CF 50

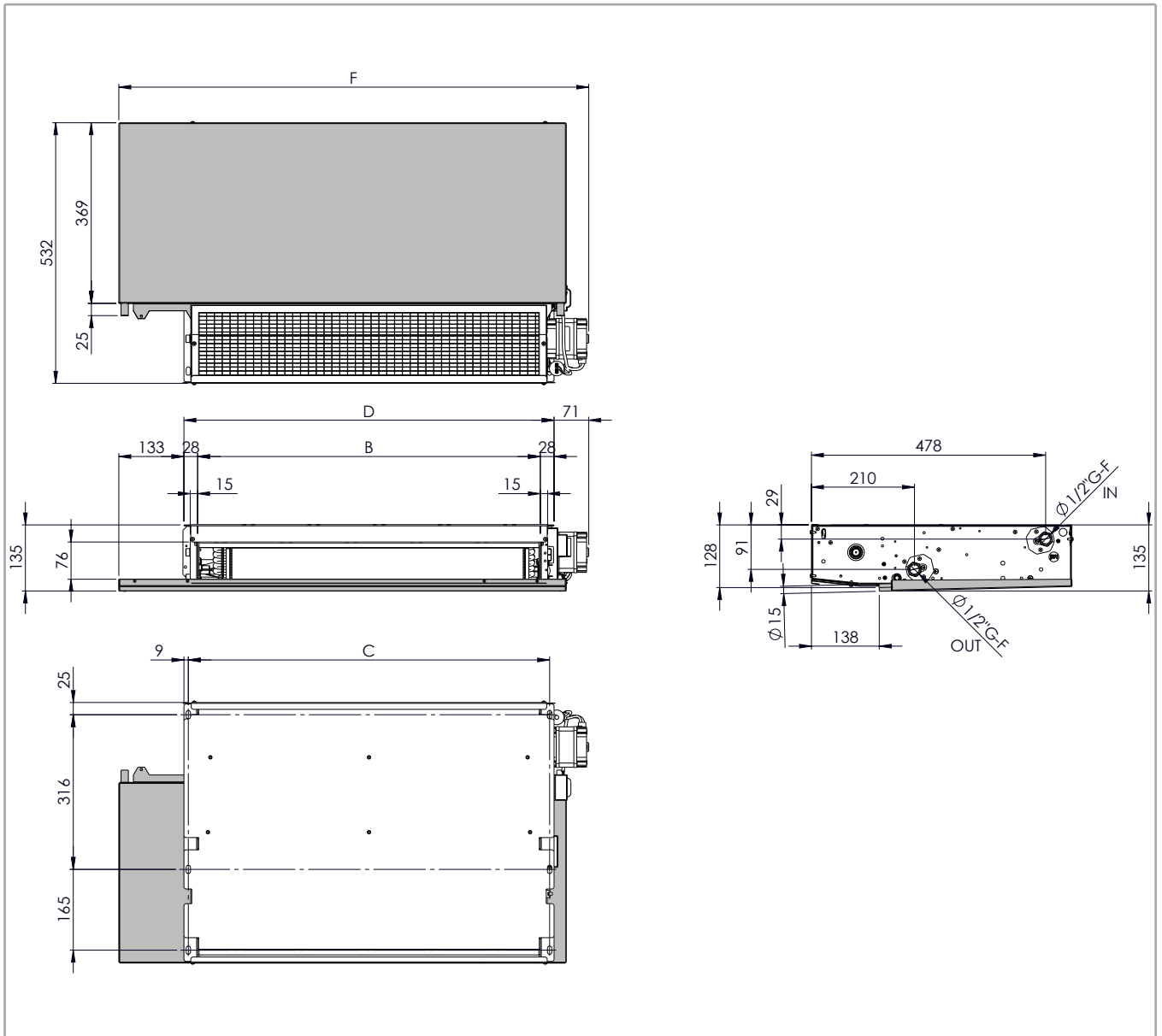

Model	B mm	C mm	D mm	F mm
10	300	338	356	560
20	500	538	556	760
30	700	738	756	960
40	900	938	956	1160
50	1100	1138	1156	1360

BREEZE frame kit for wall concealed installation

The kit is available in 3 sizes and allows the wall installation of the recessed Carisma Whisper fan coil units. The kit includes a top closing panel that prevents the access to technical spaces and coil ensuring the safety of the end user.

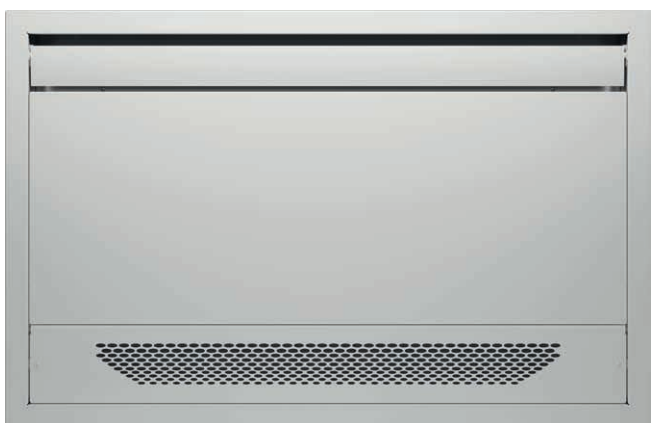

The aesthetic frame kit and the recessed box kit must be always combined together; the kits have separate codes because they are supplied in separate packagings.



The accessory can be used only for the Carisma Whisper models, IV version, sizes 20-30-40. When the Fan Coil is equipped with the Recessed box kit, it must be connected to a remote control and it is not possible to use the built-in electronic controls. With the Breeze frame kit the simplified 3 way valve kits can not be installed.

Constructional features of the main components

The aesthetic frame includes:

- the closing frame;
- the air supply louvre;
- the front panel;
- the air intake grid.

Perimeter frame, front panel and air intake grid made of steel painted with epoxy polyester coat, dried in a furnace at 180 °C, colour RAL 9003.

It is possible to repaint the entire frame of the same color as the wall.



The air supply louvre is made of extruded aluminium and painted with epoxy polyester coat, dried in a furnace at 180 °C, colour RAL 9003.



The air intake grid is fixed to the frame by using a simple and fast connecting system. The grid can be easily removed to clean the filter and the inner casing.



The recessed box is made of galvanized steel with openings for the electrical and hydraulic connections. To fit in the unit easily, there are 4 grub screws.



Aesthetic frame dimensions

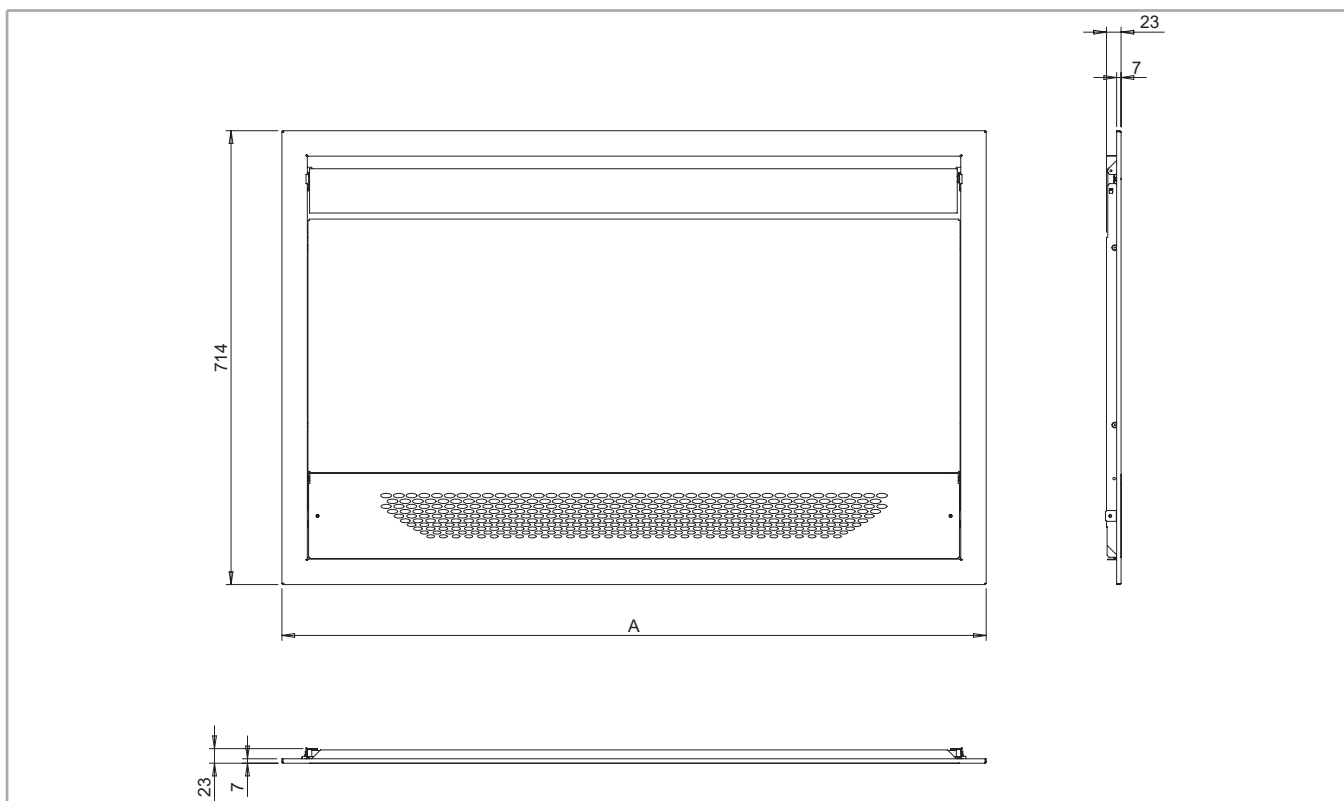

Model	A mm	Code	ID
20	908	9071162	CBF-A
30	1108	9071163	CBF-B
40	1308	9071164	CBF-C



Recessed box dimensions

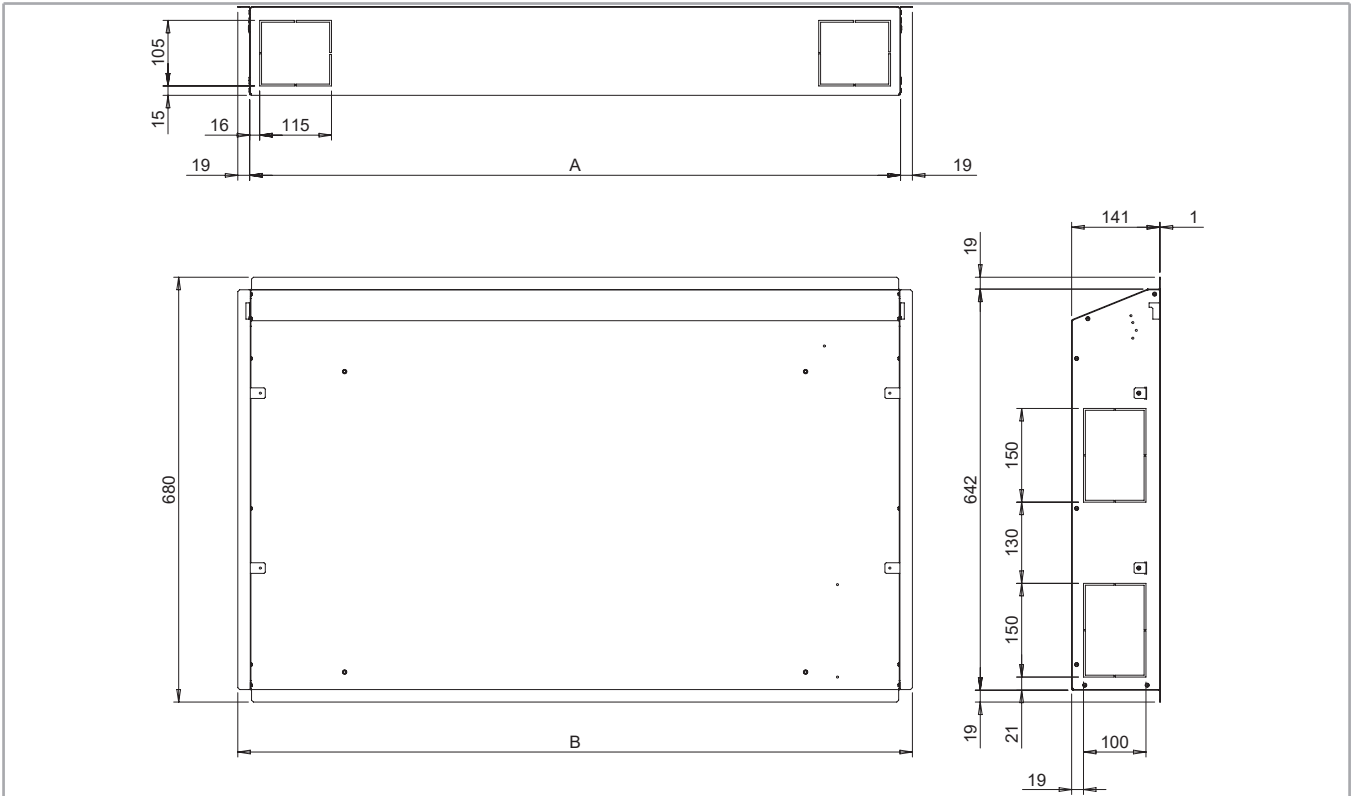

Model	A mm	B mm	Code	ID
20	842	880	9071152	IBF 2
30	1042	1080	9071153	IBF 3
40	1242	1280	9071154	IBF 4

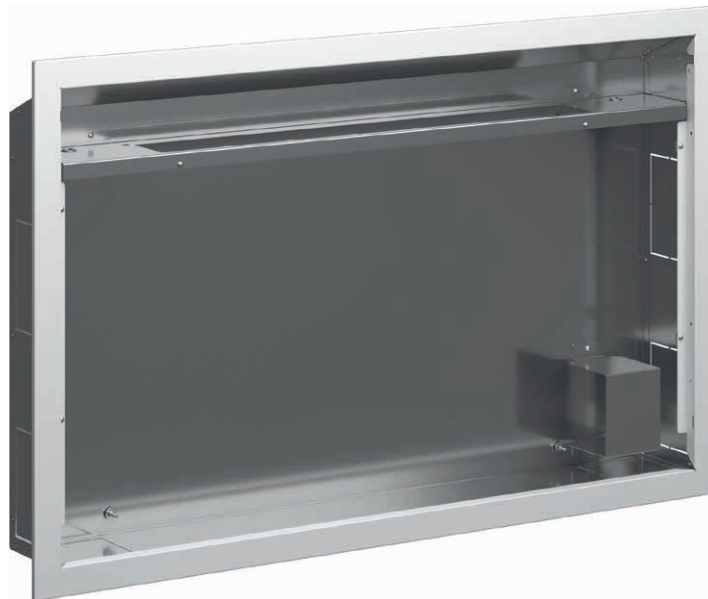



The descriptions and illustrations provided in this publication are not binding: **Sabiana** reserves the right, whilst maintaining the essential characteristics of the types described and illustrated, to make, at any time, without the requirement to promptly update this piece of literature, any changes that it considers useful for the purpose of improvement or for any other manufacturing or commercial requirements.

Il presente documento annulla e sostituisce il certificato di pari numero emesso in data 06/05/2022.



IQNet, the association of the world's first class certification bodies, is the largest provider of management System Certification in the world. IQNet is composed of more than 30 bodies and counts over 150 subsidiaries all over the globe.

CERTIFICATO N. 0545/8
 CERTIFICATE No. _____

SI CERTIFICA CHE IL SISTEMA DI GESTIONE PER LA QUALITÀ DI
 WE HEREBY CERTIFY THAT THE QUALITY MANAGEMENT SYSTEM OPERATED BY

SABIANA S.P.A.

Sede e Unità Operativa

Via Piave, 53 - 20011 Corbetta (MI) - Italia

Processi direzionali, primari e di supporto relativamente a Progettazione, produzione e assistenza di apparecchiature per il riscaldamento e il condizionamento dell'aria (aerotermi, termostrisce radianti, ventilconvettori e unità trattamento aria) e canne fumarie.

Unità Operative

Via Virgilio, 2 - 20013 Magenta (MI) - Italia

Produzione di ventilconvettori. Magazzino Logistica.

(Presente solo reparto produttivo, magazzino componenti e logistica: Magazzino P.F. e spedizione).

Via Zanella, 27 - 20011 Corbetta (MI) - Italia

Assemblaggio unità trattamento aria, lavorazioni meccaniche, saldatura, magazzino, assemblaggio recuperatori.

È CONFORME ALLA NORMA / IS IN COMPLIANCE WITH THE STANDARD

UNI EN ISO 9001:2015

Sistema di Gestione per la Qualità / Quality Management System

PER LE SEGUENTI ATTIVITÀ / FOR THE FOLLOWING ACTIVITIES

EA: 18

Progettazione, produzione e assistenza di apparecchiature per il riscaldamento e il condizionamento dell'aria (aerotermi, termostrisce radianti, ventilconvettori e unità trattamento aria) e canne fumarie.

Design, production and service of heating and air conditioning equipment (unit heaters, radiant panels, fan coil units and air handling units) and chimneys.

Riferirsi alla documentazione del Sistema di Gestione per la Qualità aziendale per l'applicabilità dei requisiti della norma di riferimento.
 Refer to the documentation of the Quality Management System for details of application to reference standard requirements.

Il presente certificato è soggetto al rispetto del documento ICIM "Regolamento per la certificazione dei sistemi di gestione" e al relativo Schema specifico.
 The use and the validity of this certificate shall satisfy the requirements of the ICIM document "Rules for the certification of company management systems" and specific Scheme.

Per informazioni puntuali e aggiornate circa eventuali variazioni intervenute nello stato della certificazione di cui al presente certificato, si prega di contattare il n° telefonico +39 02 725341 o indirizzo e-mail info@icim.it.
 For timely and updated information about any changes in the certification status referred to in this certificate, please contact the number +39 02 725341 or email address info@icim.it.

DATA EMISSIONE
 FIRST ISSUE
 10/06/1996

EMISSIONE CORRENTE
 CURRENT ISSUE
 13/05/2022

DATA DI SCADENZA
 EXPIRING DATE
 09/04/2024

Vincenzo Delacqua
 Rappresentante Direzione / Management Representative
ICIM S.p.A.

Piazza Don Enrico Mapelli, 75 - 20099 Sesto San Giovanni (MI)
 www.icim.it



SGO N° 004 A



www.cisq.com

CISQ è la Federazione Italiana di Organismi di Certificazione dei sistemi di gestione aziendali.
 CISQ is the Italian Federation of management system Certification Bodies.

0449CM_03_IT



A company of Arbonia Group
ARBONIA 

Follow us on



Sabiana app



SABIANA SpA

Società a socio unico
via Piave 53 - 20011 Corbetta (MI) Italy
T. +39 02 97203 1 r.a. - F. +39 02 9777282
info@sabiana.it
www.sabiana.it



Cert. n. 0545



Cert. n. 050153

Operative unit
via Virgilio 2, Magenta-MI Italia