



Cert. n° 0545

Radiant panels Duck Strip 4.1

TECHNICAL GUIDE



<i>INTRODUCTION</i>	2
<i>MAIN ADVANTAGES</i>	3
<i>SERIES DS-ST18 TECHNICAL SPECIFICATIONS</i>	6
<i>SERIES DS-ST18 MODELS AND DIMENSIONS</i>	7
<i>SERIES DS-ST28 TECHNICAL SPECIFICATIONS</i>	8
<i>SERIES DS-ST28 MODELS AND DIMENSIONS</i>	9
<i>DS-ST18 / 28 MODULAR LENGTHS AND HANGING BRACKET PITCHES</i>	10
<i>MAIN COMPONENTS AND OPERATION LIMITS</i>	12
<i>LENGTH MODULARITY</i>	13
<i>HEADERS AND CONNECTIONS</i>	14
<i>THERMAL EMISSIONS OF DS-ST18 RADIANT PANELS</i>	16
<i>THERMAL EMISSIONS OF DS-ST18 HEADERS</i>	17
<i>THERMAL EMISSIONS OF DS-ST28 RADIANT PANELS</i>	18
<i>THERMAL EMISSIONS OF DS-ST28 HEADERS</i>	20
<i>SERIES DS-ST18 PRESSURE DROP</i>	22
<i>SERIES DS-ST28 PRESSURE DROP</i>	24
<i>COUPLE OF HEADERS PRESSURE DROP</i>	26
<i>WEIGHT, WATER CONTENT AND FLOW RATE</i>	27
<i>HEIGHT OF INSTALLATION</i>	28
<i>EXPANSIONS</i>	29
<i>MAKE-UP JOINT</i>	30
<i>ACCESSORIES</i>	31
<i>SUSPENSIONS</i>	40
<i>PRESSFITTING</i>	41
<i>INSTALLATION AND SUPPLY DIAGRAMS</i>	42
<i>GENERAL RECOMMENDATIONS FOR INSTALLATION</i>	44
<i>ORDERING PROCEDURE</i>	45
<i>CERTIFICATION</i>	46

SYSTEM EVOLUTION NEW SABIANA DUCK STRIP RADIANT PANELS

The new Sabiana Duck Strip 4.1 radiant panel represents the maximum evolution of hot water radiant ceiling heating systems.

Built in compliance with the European Standard EN 14037 at the Sabiana facilities in Corbetta (MI), it is manufactured according to the National Industry 4.0 Plan, with industrial automation that integrates some new production technologies that improve working conditions and increase the productivity and functional quality of the plants; all this with an eye on energy consumption, creating more efficient systems and reducing any waste of energy according to the typical paradigms of Sustainable energy.

Since 1971 Sabiana, world leader in the heating and air conditioning industry, has been designing, manufacturing and selling high temperature or hot water radiant panels installed in all types of environments (small, medium and large industry, sport, commercial, recreational and zootechnical facilities, etc.) and designed to ensure the maximum possible comfort combined with high energy consumption savings.

The high construction standards and the use of high quality raw materials guarantee a product designed to last over the years, without any functional problems and with unchanged thermal efficiency.

These characteristics have led Sabiana Duck Strip radiant panels to being chosen by the most important companies worldwide, those that consider each cost item as a production investment.



- ENERGY SAVINGS:

One of the main advantages of using Duck Strip 4.1 radiant panels is represented by the substantial energy savings, compared to the use of any other type of system (air heaters, gas generators, floor panels, gas radiant panels, etc.).

In radiant heating systems, the phenomenon of air stratification is almost non-existent and therefore the heat load required for heating is considerably reduced.

The higher the buildings, the greater the percentage of energy savings.

In addition, in the radiant heating system, the design operating temperature is achieved with an air temperature that is normally 2/3 °C lower than the desired value. This results in a reduction of the heat loss.

The distribution and diffusion of heat inside the buildings takes place naturally, without the need for supporting mechanical components (motors, fans), and consequently without electricity consumption.

The Sabiana Duck Strip 4.1 radiant panels do not require special maintenance and ensure long service life and unchanged thermal efficiency over time.

A building with a long-lasting heating system, low maintenance costs, low energy consumption and high comfort has a higher market value.

Directive 2002/91 of the European Parliament of 16.12.2002, concerning the energy efficiency of buildings, requires, as of 2006, new buildings to have a minimum energy efficiency: this is affected by the chosen heating system.

This directive will be the basis for estimating the economic value of the building in terms of energy consumption.

- COMPLIANT WITH STANDARD EN 14037:

The thermal emission of Sabiana Duck Strip 4.1 panels was obtained by applying the harmonised European standard EN 14037, approved in 2003, which accurately defines the test method for determining the thermal emission of the panels.

This standard also indicates the specifications and technical requirements for hot water radiant ceiling panels, technical specifications of the paintwork and insulation padding, stability and tightness of the panels and suspensions, resistance to pressure and construction tolerances, and guarantees the quality of the product.

Since, in the standard, explicit reference is made to Directive 89/106/EEC on construction products, the CE mark on the product is mandatory by law and the product can only be sold in the presence of test certificates issued by authorised European laboratories.



• INDOOR COMFORT:

Among the different types of industrial heating, radiant heating ensures by far the best comfort for people, reflecting what occurs in nature with the Earth's crust being heated by sunlight.

The operating temperature is the arithmetic average between air temperature and average radiant temperature; it is therefore clear that a radiant heating system ensures well-being in the premises, with air at a lower and healthier temperature.

With a correct design it is easy to obtain an even operating temperature in every point of the premises, or reduce the temperature in areas where staff does not actually work.

In addition, the possibility of modulating the water flow temperature according to the changes in the external weather conditions, ensures an optimum adaptation of the radiant temperature that will not cause perceptible oscillations of the operating temperature.

The floor is heated to a temperature approximately equal to the comfort temperature, eliminating the inconvenience of cold feet.

A radiant heating system does not require air movements, thus preventing bothersome cooler or warmer currents and eliminating the inconvenience of dust or suspended dust, all in total silence.

• WIDE RANGE AND EASY INSTALLATION:

Sabiana has significantly expanded the range of radiant panel models available with the introduction of two new versions; the first one featuring 18 mm diameter pipes (with variable pitches of 75 mm or 100 mm) and the second one featuring 28 mm pipes (with 150 mm pitch), for a total of 18 different types.

The extensive selection, in addition to the wide range of accessories available, enables thermal engineering designers to meet all possible plant requirements, due to the different characteristics of each room to be heated.

Using 18 mm and 28 mm diameter pipes makes it possible to use pressfittings, which are easy to find on the market, ensuring tightness over time.

The new side profile designed for the Duck Strip 4.1 radiant panels is raised, ensuring easy positioning of the insulation padding.

The wide range of available headers, supplied already welded on the end heads, enable the system to be designed in the best way possible with limited use of hydraulic pipes.



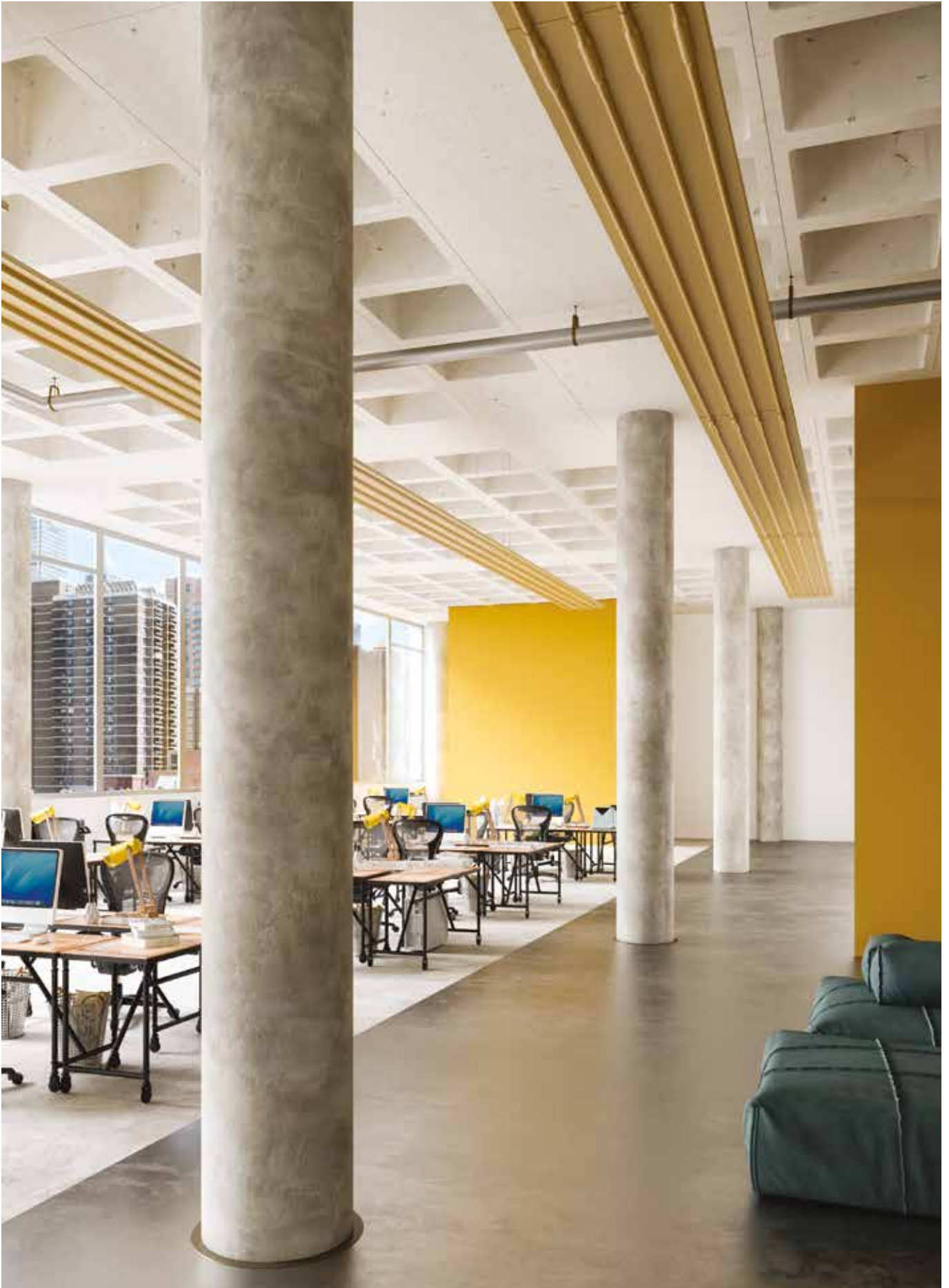

- Radiant panel made of 0.8 mm thick high quality steel.
- 18 mm diameter electro-welded steel pipes with smooth ends for joining with pressfittings.
- Pipe/Plate connection made by spot welding.
- Pipe pitch 100 mm (DS-ST18-3) or 75 mm (DS-ST18-4).
- Square section headers welded at the factory on the first and final sections.
- Possibility of raised header.
- Angle brackets.
- Sheet metal retaining clips for fastening the fibreglass insulation.
- Shaped and painted make-up joints for covering the junction area.
- Protection with a special phosphodegreasing process and epoxy-polyester powder coating, dried in a furnace at 180 °C - RAL 9016 (white) or RAL 9002 (light grey), in compliance with Directive 76/769/EEC. Other RAL colours available on request.
- Fibreglass insulation available (supplied in bulk rolls) with 30 mm standard thickness (or 40 mm on request) with 25 micron aluminium sheet support:
 - reaction to fire class: A1 according to Standard EN 13501-1;
 - thermal conductivity at 20 °C: 0.036 W/mK for 30 mm thickness (0.034 W/mK for 40 mm thickness);
 - density: 20 kg/m³ for 30 mm thickness (25 kg/m³ for 40 mm thickness);
 - thermal resistance: 0.83 m²K/W for 30 mm thickness (1.17 m²K/W for 40 mm thickness).
- Emission of the radiant surface $\epsilon = 0,96$.

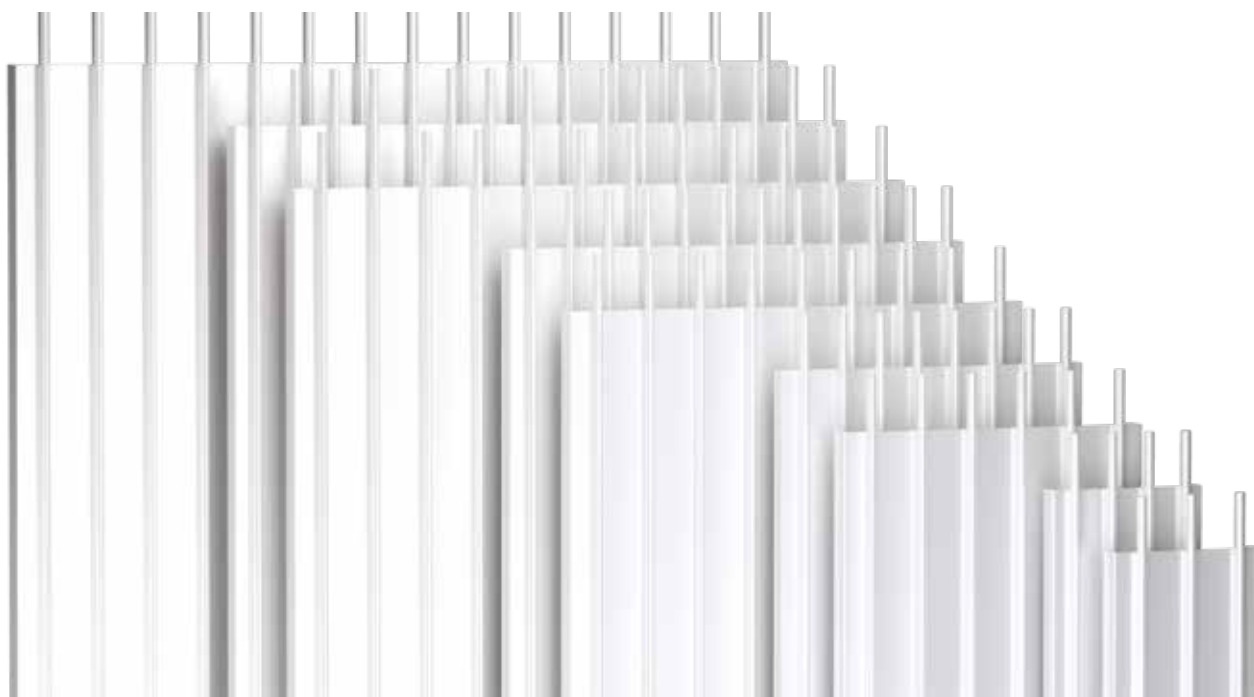

Pipes 18 mm ϕ , 100 mm pitch

DS-ST18-3-030; 3 Pipes

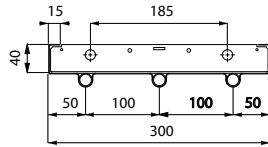

DS-ST18-3-060; 6 Pipes

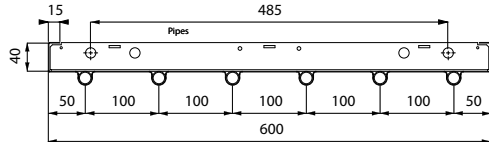

DS-ST18-3-090; 9 Pipes

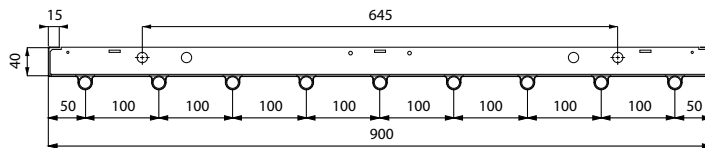

DS-ST18-3-120; 12 Pipes

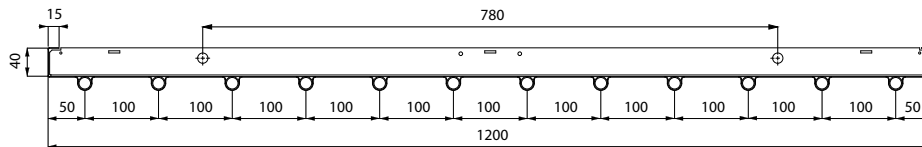

DS-ST18-3-150; 15 Pipes

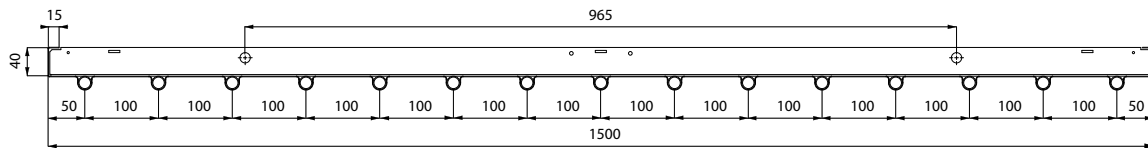

Pipes 18 mm ϕ , 75 mm pitch

DS-ST18-4-030; 4 Pipes

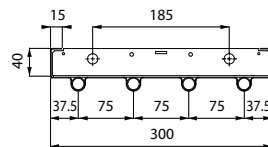

DS-ST18-4-060; 8 Pipes

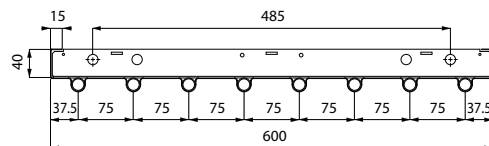

DS-ST18-4-090; 12 Pipes

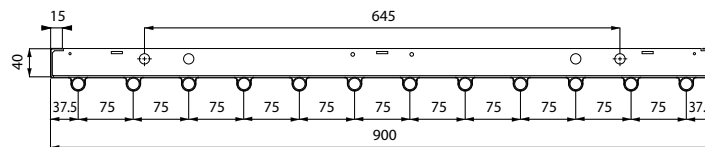

DS-ST18-4-120; 16 Pipes

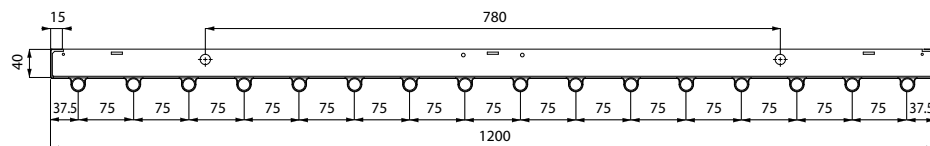

- Radiant panel made of 1.2 mm thick high quality steel.
- 28 mm diameter electro-welded steel pipes with smooth ends for joining with pressfittings.
- Pipe/Plate connection made by spot welding.
- Version with special pipe for high temperature hot water systems (DS-SP).
- Pipe pitch 150 mm.
- Square section headers welded at the factory on the first and final sections.
- Possibility of raised header.
- Angle brackets.
- Sheet metal retaining clips for fastening the fibreglass insulation.
- Protection with a special phosphodegreasing process and epoxy-polyester powder coating, dried in a furnace at 180 °C - RAL 9016 (white) or RAL 9002 (light grey), in compliance with Directive 76/769/EEC. Other RAL colours available on request.
- Fibreglass insulation available (supplied in bulk rolls) with 30 mm standard thickness (or 40 mm on request) with 25 micron aluminium sheet support:
 - reaction to fire class: A1 according to Standard EN 13501-1;
 - thermal conductivity at 20 °C: 0.036 W/mK for 30 mm thickness (0.034 W/mK for 40 mm thickness);
 - density: 20 kg/m³ for 30 mm thickness (25 kg/m³ for 40 mm thickness);
 - thermal resistance: 0.83 m²K/W for 30 mm thickness (1.17 m²K/W for 40 mm thickness).
- Radiant surface emission $\epsilon = 0,96$.



Pipes 28 mm ϕ , 150 mm pitch

DS-ST28-2-030; 2 Pipes

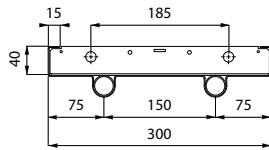

DS-ST28-2-045; 3 Pipes

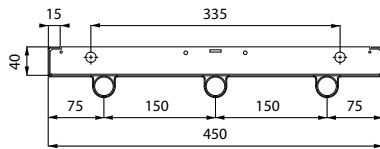

DS-ST28-2-060; 4 Pipes

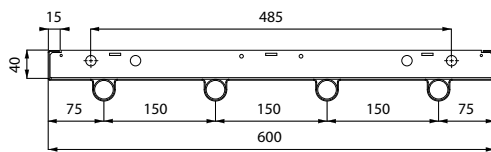

DS-ST28-2-075; 5 Pipes

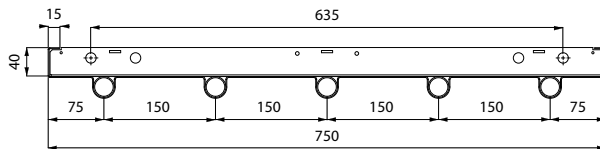

DS-ST28-2-090; 6 Pipes

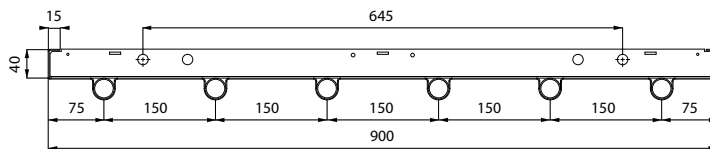

DS-ST28-2-105; 7 Pipes

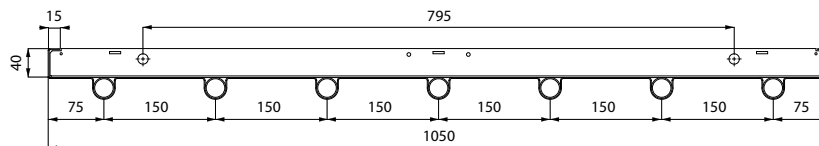

DS-ST28-2-120; 8 Pipes

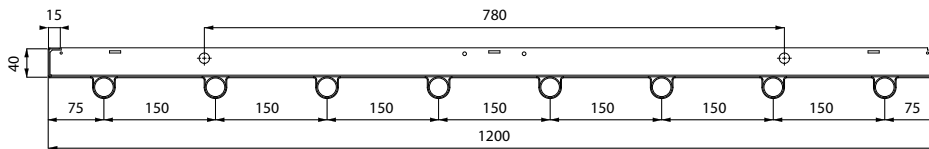

DS-ST28-2-135; 9 Pipes

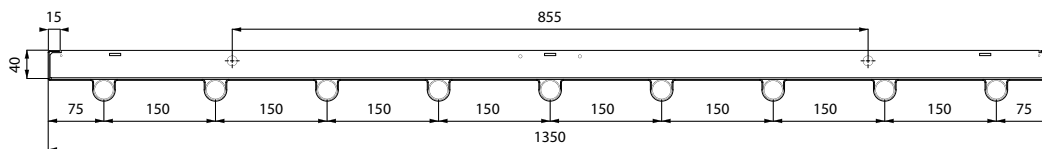

DS-ST28-2-150; 10 Pipes

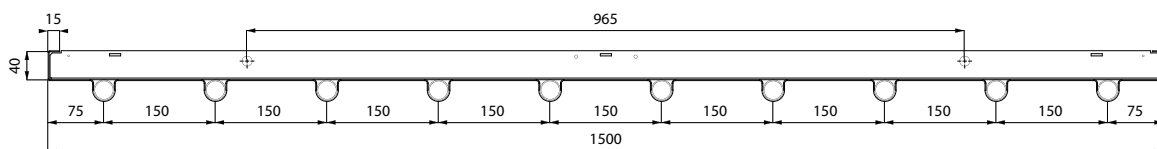

Duck Strip 4.1 | DS-ST18 / 28 MODULAR LENGTHS AND HANGING BRACKET PITCHES



Start and final head

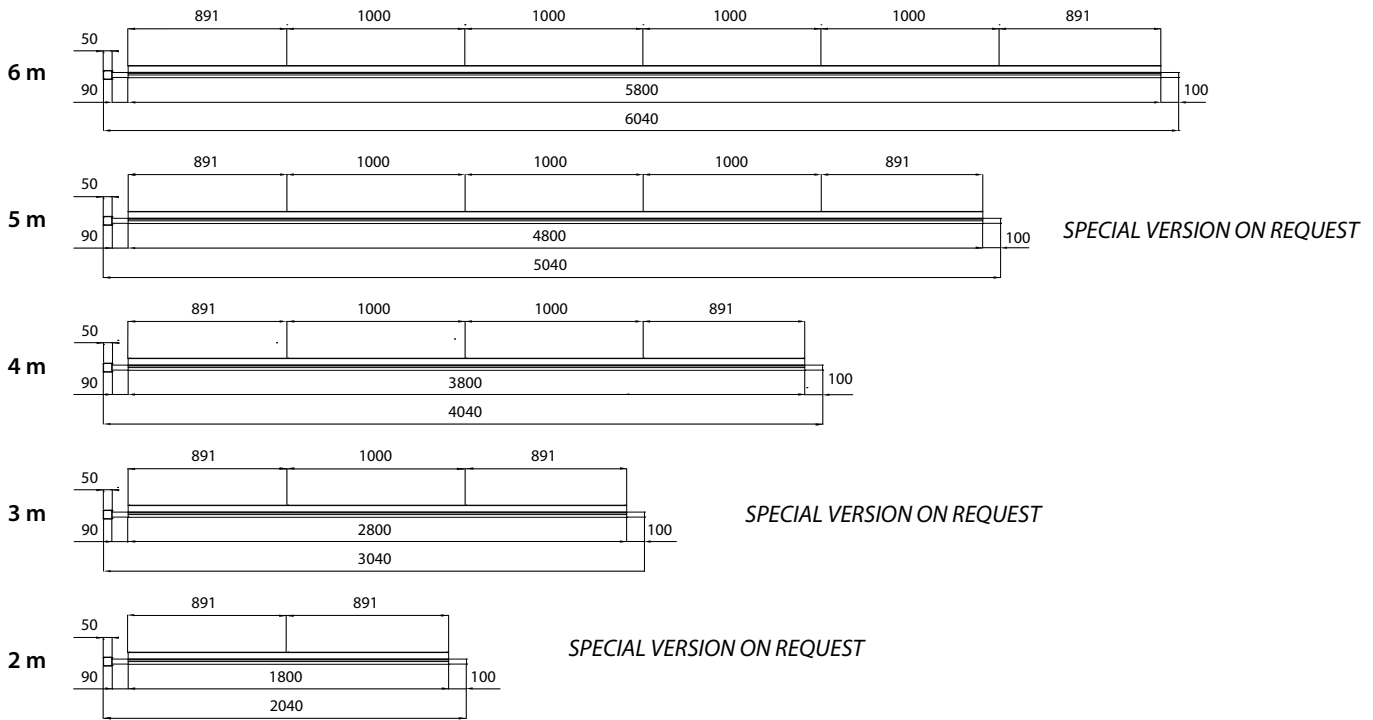

Intermediate

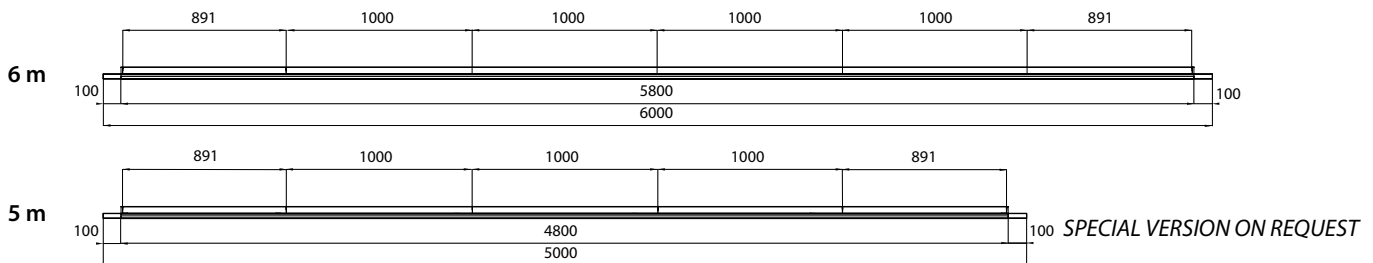

Double heads

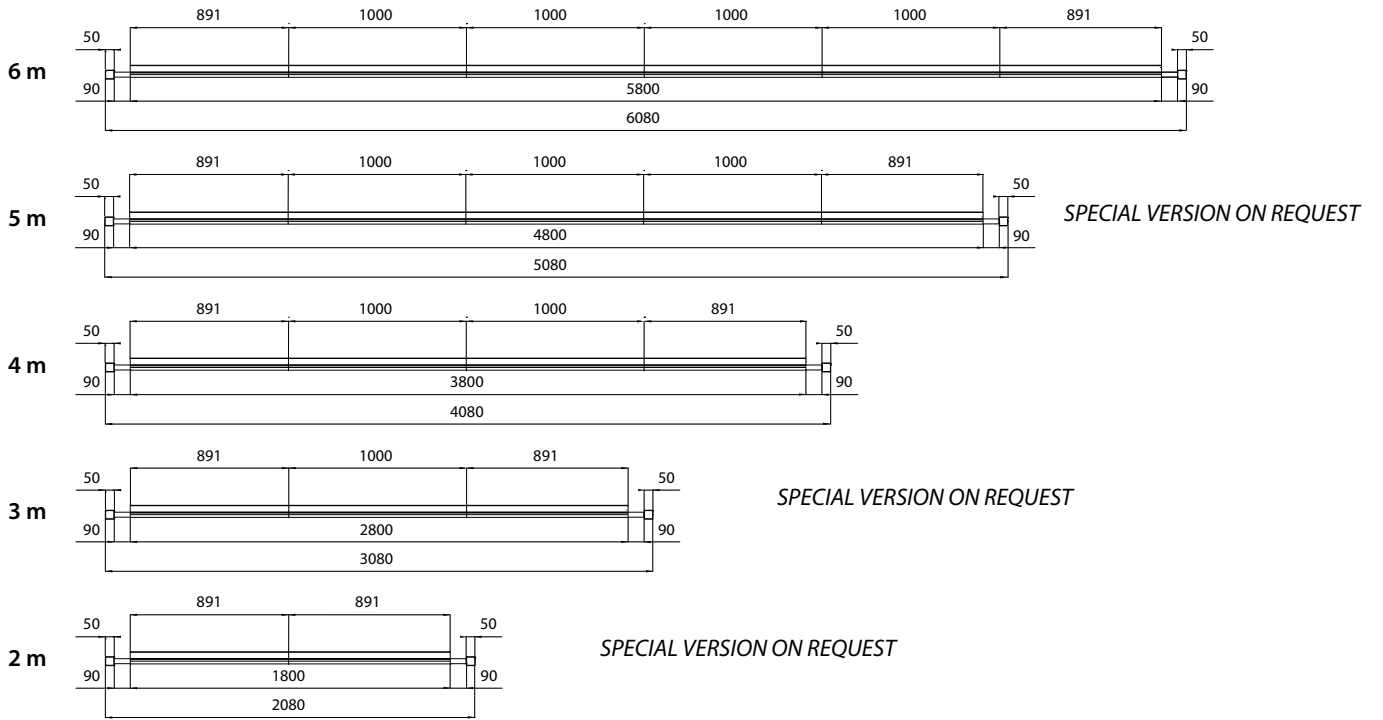

GENERAL COMPONENT DIAGRAM

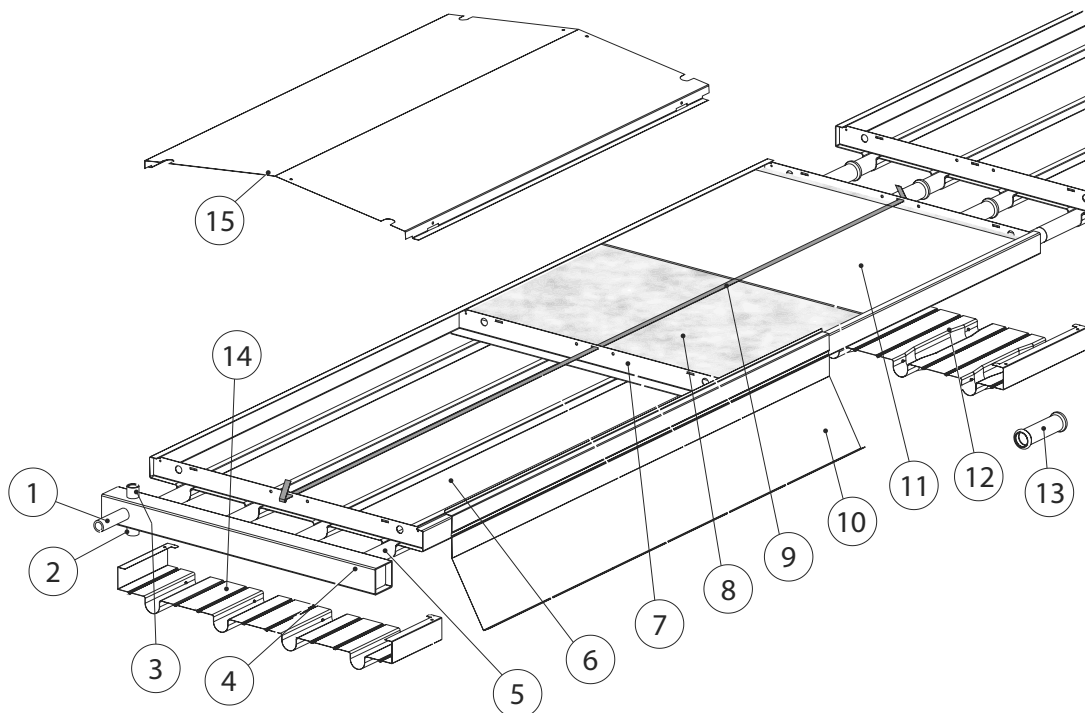

1. Threaded male connection ($\text{Ø } 1/2'' - 3/4'' - 1'' - 1.1/4''$)
2. Water drain connection $\text{Ø } 3/8''$
3. Air vent connection $\text{Ø } 3/8''$
4. First or end header
5. Steel pipe
6. Steel radiant panel
7. Hanging bracket
8. Fibreglass insulation
9. Insulation retaining clip
10. Anti-convective skirt (on request)
11. Cover panel (on request)
12. Make-up joint (supplied as standard)
13. Pressfitting (on request)
14. Make-up joint between panel and header (on request)
15. Upper plate for gyms (on request)

OPERATION LIMITS

Standard Version:

- Pipe diameter 18 mm and 28 mm
- Maximum water inlet temperature 120 °C
 - Maximum operating pressure 10 bar

Special Version:

- Pipe diameter 28 mm
- Maximum water inlet temperature 180 °C
 - Maximum operating pressure 16 bar

The first and the intermediate sections of the Duck Strip radiant panels can be joined together by pressfittings, in order to compose all the desired lengths. The maximum distance between each suspension is 2 m.

Installation example:

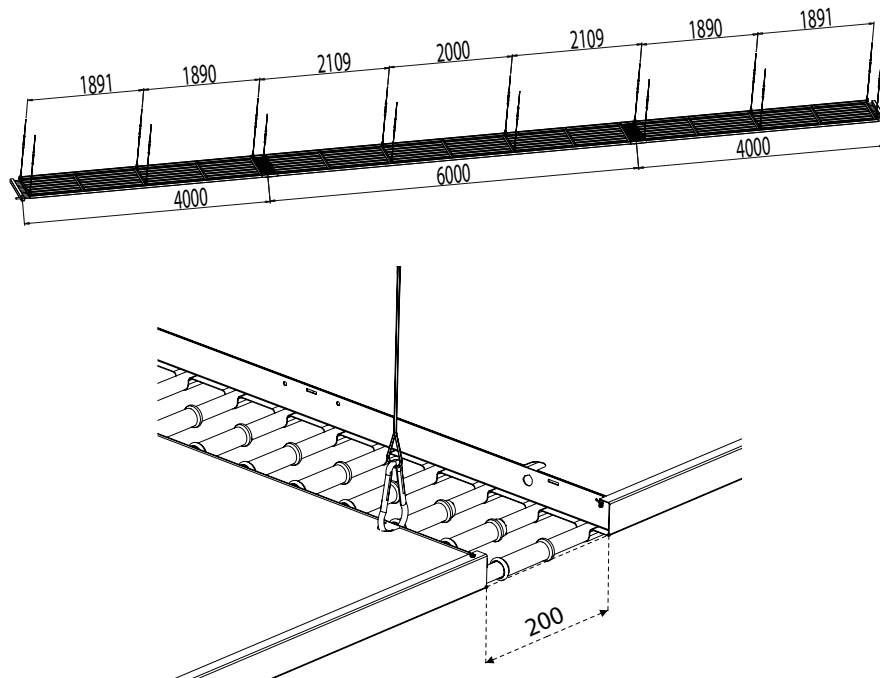

Table of the length compositions of the first, intermediate and final sections

L	FIRST	INTERMEDIATE	FINAL
4 m	1 x 4 m*	-	-
6 m	1 x 6 m *	-	-
8 m	1 x 4 m	-	1 x 4 m
10 m	1 x 4 m	-	1 x 6 m
12 m	1 x 6 m	-	1 x 6 m
14 m	1 x 4 m	1 x 6 m	1 x 4 m
16 m	1 x 4 m	1 x 6 m	1 x 6 m
18 m	1 x 6 m	1 x 6 m	1 x 6 m
20 m	1 x 4 m	2 x 6 m	1 x 4 m
22 m	1 x 4 m	2 x 6 m	1 x 6 m
24 m	1 x 6 m	2 x 6 m	1 x 6 m
26 m	1 x 4 m	3 x 6 m	1 x 4 m

L	FIRST	INTERMEDIATE	FINAL
28 m	1 x 4 m	3 x 6 m	1 x 6 m
30 m	1 x 6 m	3 x 6 m	1 x 6 m
32 m	1 x 4 m	4 x 6 m	1 x 4 m
34 m	1 x 4 m	4 x 6 m	1 x 6 m
36 m	1 x 6 m	4 x 6 m	1 x 6 m
38 m	1 x 4 m	5 x 6 m	1 x 4 m
40 m	1 x 4 m	5 x 6 m	1 x 6 m
42 m	1 x 6 m	5 x 6 m	1 x 6 m
44 m	1 x 4 m	6 x 6 m	1 x 4 m
46 m	1 x 4 m	6 x 6 m	1 x 6 m
48 m	1 x 6 m	6 x 6 m	1 x 6 m
50 m	1 x 4 m	7 x 6 m	1 x 4 m

* Complete sections with 2 headers.

"B" Model 5 - 6 Connections

Mod.	L
030	300
045	450
060	600
075	750
090	900
105	1050
120	1200
135	1350
150	1500

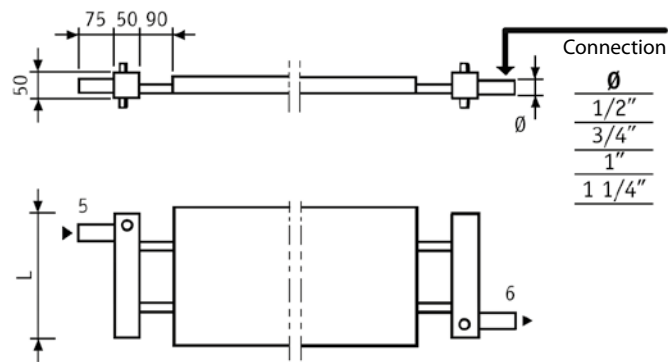

"B" Model 7 - 8 Connections

Mod.	L
030	300
045	450
060	600
075	750
090	900
105	1050
120	1200
135	1350
150	1500

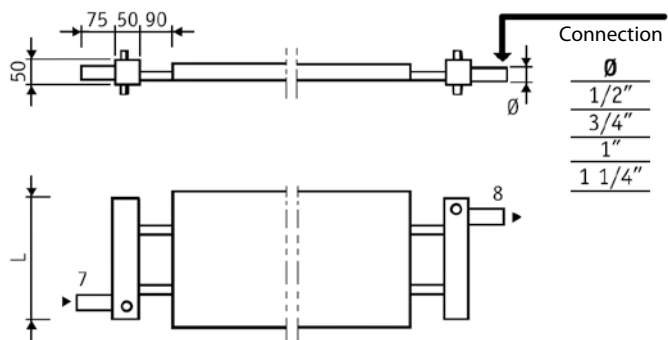

"D" Model

Mod.	L	A
030	300	200
045	450	350
060	600	500
075	750	650
090	900	800
105	1050	950
120	1200	1100
135	1350	1250
150	1500	1400

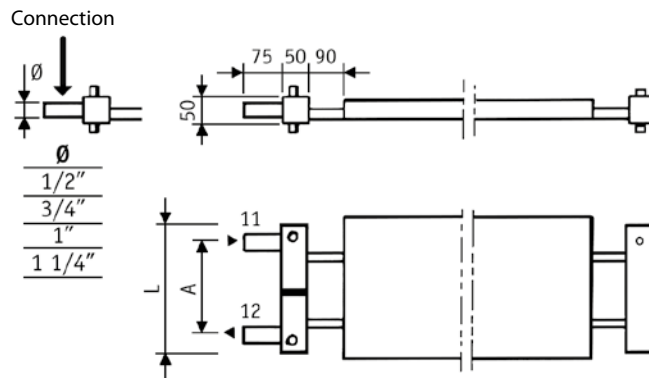

"D + D" Model

Mod.	L	A
030	300	200
045	450	350
060	600	500
075	750	650
090	900	800
105	1050	950
120	1200	1100
135	1350	1250
150	1500	1400

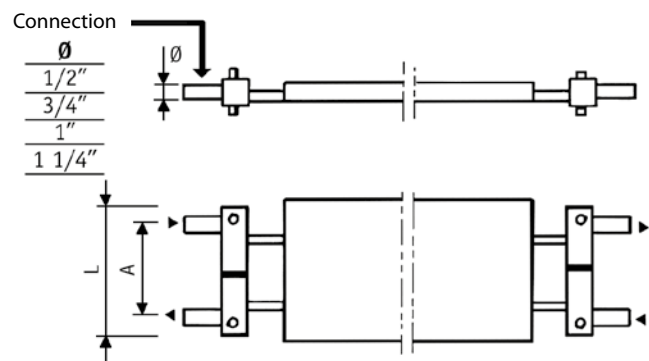

Warning!

D and D+D headers are not suitable for high temperature hot water.

"D" header can be used with hot water up to lines with a maximum length of 50 m and using slow and soft opening valves.

"G" Model

Mod.	L	A
120	1200	1100
135	1350	1250
150	1500	1400

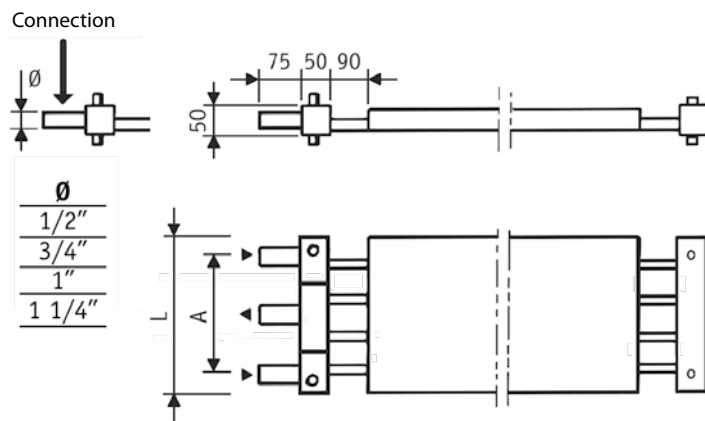



SERIES DS-ST18 - Thermal emissions for each meter according to European Standard EN 14037-3

	18-3-030	18-3-060	18-3-090	18-3-120	18-3-150
K	1,933	3,247	4,448	5,731	7,173
n	1,159	1,157	1,173	1,169	1,164
Δtm(K)	W/m	W/m	W/m	W/m	W/m
20	62	104	149	190	234
22	70	116	167	213	262
24	77	128	185	235	290
26	84	141	203	258	318
28	92	153	222	282	347
30	100	166	240	305	376
32	107	179	259	329	405
34	115	192	278	354	435
36	123	205	298	378	465
38	131	218	317	403	495
40	139	232	337	428	525
42	147	245	357	453	556
44	155	259	377	478	587
46	163	272	397	503	618
48	172	286	417	529	650
50	180	300	438	555	681
52	188	314	458	581	713
54	197	328	479	607	745
55	201	335	489	620	761
56	205	342	500	634	777
58	214	356	521	660	810
60	222	371	542	687	842
62	231	385	563	714	875
64	240	399	585	741	908
65	244	406	595	754	925
66	248	414	606	768	941
68	257	428	628	795	974
70	266	443	649	823	1008
72	275	458	671	850	1041
74	284	472	693	878	1075
76	292	487	715	906	1109
78	301	502	737	933	1143
80	310	517	759	961	1177
82	319	532	782	990	1212
84	328	547	804	1018	1246
86	338	562	827	1046	1281
88	347	577	849	1075	1315
90	356	592	872	1103	1350
92	365	608	895	1132	1385
94	374	623	918	1161	1420
96	383	638	941	1190	1456
98	393	654	964	1219	1491
100	402	669	987	1248	1527

18-4-030	18-4-060	18-4-090	18-4-120
2,075	3,354	4,569	5,852
1,161	1,175	1,182	1,182
W/m	W/m	W/m	W/m
67	113	158	202
75	127	176	226
83	140	196	250
91	154	215	275
99	168	235	301
108	182	255	326
116	197	275	352
124	211	295	378
133	226	316	404
142	241	337	431
150	256	358	458
159	271	379	485
168	286	400	513
177	302	422	540
186	317	444	568
195	333	466	596
204	348	488	625
213	364	510	653
218	372	521	667
222	380	532	682
231	396	555	711
241	412	578	740
250	428	600	769
259	444	623	798
264	453	635	813
269	461	646	828
278	477	670	858
288	494	693	888
297	510	716	918
307	527	740	948
317	544	764	978
326	561	788	1009
336	578	811	1039
346	595	836	1070
356	612	860	1101
366	629	884	1132
375	646	908	1163
385	663	933	1195
395	681	957	1226
405	698	982	1258
415	716	1007	1289
425	733	1031	1321
436	751	1056	1353

Δtm (K) = difference between the mean water temperature and the room temperature
 K = coefficient related to the heating body
 n = exponent related to the heating body

The thermal emissions are calculated according to the following fomula: $Q = K \cdot (\Delta tm)^n$
 The tests have been carried out by Kermi GmbH laboratory in Plattling, Germany

SERIES DS-ST18 - Thermal emissions for a couple of headers according to European Standard EN 14037-3

	18-3-030	18-3-060	18-3-090	18-3-120	18-3-150	18-4-030	18-4-060	18-4-090	18-4-120
K	0,393	0,779	1,177	1,582	1,962	0,435	0,861	1,305	1,757
n	1,216	1,216	1,216	1,216	1,216	1,235	1,235	1,235	1,235
Δtm(K)	W	W	W	W	W	W	W	W	W
20	30	60	90	121	150	35	70	106	142
22	34	67	101	136	168	40	78	119	160
24	37	74	112	151	187	44	87	132	178
26	41	82	124	166	206	49	96	146	196
28	45	90	135	182	226	53	106	160	215
30	49	97	147	198	245	58	115	174	234
32	53	105	159	214	265	63	124	189	254
34	57	113	171	230	286	68	134	203	274
36	61	122	184	247	306	73	144	218	294
38	66	130	196	264	327	78	154	233	314
40	70	138	209	281	348	83	164	248	334
42	74	147	222	298	369	88	174	264	355
44	78	155	235	315	391	93	184	279	376
46	83	164	248	333	413	98	195	295	397
48	87	173	261	350	435	104	205	311	419
50	91	181	274	368	457	109	216	327	441
52	96	190	287	386	479	114	227	343	462
54	100	199	301	404	502	120	237	360	485
55	103	204	308	414	513	123	243	368	496
56	105	208	314	423	524	125	248	376	507
58	110	217	328	441	547	131	259	393	529
60	114	226	342	460	570	137	270	410	552
62	119	236	356	478	593	142	282	427	575
64	124	245	370	497	617	148	293	444	598
65	126	249	377	507	628	151	299	452	609
66	128	254	384	516	640	154	304	461	621
68	133	264	398	535	664	159	316	478	644
70	138	273	413	554	688	165	327	496	668
72	143	283	427	574	712	171	339	513	691
74	147	292	441	593	736	177	350	531	715
76	152	302	456	613	760	183	362	549	739
78	157	311	471	632	784	189	374	567	763
80	162	321	485	652	809	195	386	585	787
82	167	331	500	672	834	201	398	603	812
84	172	341	515	692	858	207	410	621	836
86	177	351	530	712	883	213	422	639	861
88	182	361	545	732	908	219	434	658	886
90	187	371	560	753	933	225	446	676	911
92	192	381	575	773	959	232	458	695	936
94	197	391	590	794	984	238	471	714	961
96	202	401	606	814	1010	244	483	732	986
98	207	411	621	835	1035	250	496	751	1012
100	213	421	637	856	1061	257	508	770	1037

Δtm (K) = difference between the mean water temperature and the room temperature
 K = coefficient related to the heating body
 n = exponent related to the heating body

The thermal emissions are calculated according to the following formula: $Q = K \cdot (\Delta tm)^n$
 The tests have been carried out by Kerma GmbH laboratory in Plattling, Germany



SERIES DS-ST28 - Thermal emissions for each meter according to European Standard EN 14037-3

	28-2-030	28-2-045	28-2-060	28-2-075	28-2-090	28-2-105	28-2-120	28-2-135	28-2-150
K	1,794	2,514	3,09	3,938	4,75	5,137	5,838	6,472	7,075
n	1,165	1,156	1,165	1,162	1,155	1,169	1,17	1,17	1,17
Δtm(K)	W/m	W/m	W/m	W/m	W/m	W/m	W/m	W/m	W/m
20	59	80	101	128	151	170	194	215	235
22	66	90	113	143	169	191	217	241	263
24	73	99	125	158	187	211	240	267	291
26	80	109	138	174	205	232	264	293	320
28	87	118	150	189	223	253	288	319	349
30	94	128	162	205	241	274	312	346	378
32	102	138	175	221	260	295	337	373	408
34	109	148	188	237	279	317	361	401	438
36	117	158	201	253	298	339	386	428	468
38	124	168	214	270	317	361	412	456	499
40	132	179	227	286	337	383	437	485	530
42	140	189	240	303	356	406	463	513	561
44	147	200	254	320	376	428	489	542	592
46	155	210	267	337	396	451	515	571	624
48	163	221	281	354	415	474	541	600	656
50	171	231	295	371	436	498	568	629	688
52	179	242	308	388	456	521	594	659	720
54	187	253	322	406	476	544	621	689	753
55	191	258	329	415	486	556	635	703	769
56	195	264	336	423	496	568	648	718	785
58	203	275	350	441	517	592	675	749	818
60	212	286	364	459	538	616	703	779	851
62	220	297	379	476	558	640	730	809	885
64	228	308	393	494	579	664	758	840	918
65	232	313	400	503	590	676	772	855	935
66	236	319	407	512	600	688	785	871	952
68	245	330	422	530	621	713	813	902	986
70	253	341	436	549	642	737	841	933	1020
72	262	353	451	567	664	762	870	964	1054
74	270	364	465	585	685	787	898	995	1088
76	279	375	480	604	706	812	926	1027	1123
78	287	387	495	622	728	837	955	1059	1157
80	296	398	509	641	749	862	984	1091	1192
82	304	410	524	659	771	887	1013	1123	1227
84	313	422	539	678	793	912	1042	1155	1262
86	322	433	554	697	815	938	1071	1187	1297
88	330	445	569	716	837	963	1100	1219	1333
90	339	457	584	735	859	989	1129	1252	1368
92	348	468	599	754	881	1015	1158	1284	1404
94	357	480	615	773	903	1041	1188	1317	1440
96	366	492	630	792	925	1067	1218	1350	1476
98	375	504	645	811	947	1093	1247	1383	1512
100	384	516	661	830	970	1119	1277	1416	1548

Δtm (K) = difference between the mean water temperature and the room temperature
 K = coefficient related to the heating body
 n = exponent related to the heating body

The thermal emissions are calculated according to the following formula: $Q = K \cdot (\Delta tm)^n$
 The tests have been carried out by Kermi GmbH laboratory in Plattling, Germany

SERIES DS-ST28 - Thermal emissions for each meter according to European Standard EN 14037-3

	28-2-030	28-2-045	28-2-060	28-2-075	28-2-090	28-2-105	28-2-120	28-2-135	28-2-150
K	1,794	2,514	3,09	3,938	4,75	5,137	5,838	6,472	7,075
n	1,165	1,156	1,165	1,162	1,155	1,169	1,17	1,17	1,17
$\Delta t_m(K)$	W/m	W/m	W/m	W/m	W/m	W/m	W/m	W/m	W/m
102	393	528	676	850	992	1145	1307	1449	1584
104	401	540	692	869	1015	1171	1337	1482	1621
106	410	552	707	889	1037	1198	1367	1516	1657
108	420	564	723	908	1060	1224	1398	1549	1694
110	429	576	738	928	1083	1251	1428	1583	1730
112	438	588	754	947	1105	1277	1458	1617	1767
114	447	600	770	967	1128	1304	1489	1651	1804
116	456	612	785	987	1151	1331	1519	1684	1841
118	465	624	801	1006	1174	1357	1550	1718	1879
120	474	637	817	1026	1197	1384	1581	1753	1916
122	484	649	833	1046	1220	1411	1612	1787	1953
124	493	661	849	1066	1243	1439	1643	1821	1991
126	502	674	865	1086	1267	1466	1674	1856	2028
128	511	686	881	1106	1290	1493	1705	1890	2066
130	521	698	897	1126	1313	1520	1736	1925	2104
132	530	711	913	1147	1336	1548	1767	1959	2142
134	539	723	929	1167	1360	1575	1799	1994	2180
136	549	736	945	1187	1383	1603	1830	2029	2218
138	558	748	961	1207	1407	1630	1862	2064	2256
140	568	761	978	1228	1430	1658	1893	2099	2295

$\Delta t_m (K)$ = difference between the mean water temperature and the room temperature
 K = coefficient related to the heating body
 n = exponent related to the heating body

The thermal emissions are calculated according to the following formula: $Q = K \cdot (\Delta t_m)^n$
 The tests have been carried out by Kermi GmbH laboratory in Plattling, Germany



SERIES DS-ST28 - Thermal emissions of a couple of headers according to European Standard EN 14037-3

	28-2-030	28-2-045	28-2-060	28-2-075	28-2-090	28-2-105	28-2-120	28-2-135	28-2-150
K	0,377	0,567	0,747	0,944	1,132	1,320	1,526	1,698	1,887
n	1,257	1,257	1,257	1,257	1,257	1,257	1,257	1,257	1,257
Δtm(K)	W	W	W	W	W	W	W	W	W
20	33	49	65	82	98	114	132	147	163
22	37	55	73	92	110	129	149	165	184
24	41	62	81	103	123	143	166	184	205
26	45	68	90	113	136	159	183	204	227
28	50	75	98	124	149	174	201	224	249
30	54	82	107	136	163	190	219	244	271
32	59	88	116	147	177	206	238	265	294
34	63	95	126	159	191	222	257	286	318
36	68	103	135	171	205	239	276	307	341
38	73	110	145	183	219	256	295	329	365
40	78	117	154	195	234	273	315	351	390
42	83	124	164	207	248	290	335	373	414
44	88	132	174	220	263	307	355	395	439
46	93	140	184	232	279	325	376	418	464
48	98	147	194	245	294	343	396	441	490
50	103	155	204	258	309	361	417	464	516
52	108	163	214	271	325	379	438	488	542
54	113	171	225	284	341	397	459	511	568
55	116	175	230	291	349	407	470	523	581
56	119	179	235	297	357	416	481	535	595
58	124	187	246	311	373	435	503	559	621
60	130	195	257	324	389	454	524	584	649
62	135	203	268	338	405	473	547	608	676
64	141	211	278	352	422	492	569	633	703
65	143	215	284	359	430	502	580	645	717
66	146	220	289	366	439	511	591	658	731
68	152	228	300	380	455	531	614	683	759
70	157	237	312	394	472	551	637	708	787
72	163	245	323	408	489	571	660	734	816
74	169	254	334	422	506	591	683	760	844
76	174	262	346	437	524	611	706	786	873
78	180	271	357	451	541	631	729	812	902
80	186	280	369	466	559	651	753	838	931
82	192	289	380	480	576	672	777	864	960
84	198	297	392	495	594	693	801	891	990
86	204	306	404	510	612	713	825	918	1020
88	210	315	415	525	630	734	849	944	1050
90	216	324	427	540	648	755	873	972	1080
92	222	333	439	555	666	776	898	999	1110
94	228	343	451	570	684	798	922	1026	1140
96	234	352	464	586	702	819	947	1054	1171
98	240	361	476	601	721	841	972	1081	1202
100	246	370	488	617	739	862	997	1109	1233

Δtm (K) = difference between the mean water temperature and the room temperature
 K = coefficient related to the heating body
 n = exponent related to the heating body

The thermal emissions are calculated according to the following formula: $Q = K \cdot (\Delta tm)^n$
 The tests have been carried out by Kermi GmbH laboratory in Plattling, Germany

SERIES DS-ST28 - Thermal emissions of a couple of headers according to European Standard EN 14037-3

	28-2-030	28-2-045	28-2-060	28-2-075	28-2-090	28-2-105	28-2-120	28-2-135	28-2-150
K	0,377	0,567	0,747	0,944	1,132	1,320	1,526	1,698	1,887
n	1,257	1,257	1,257	1,257	1,257	1,257	1,257	1,257	1,257
Δtm(K)	W	W	W	W	W	W	W	W	W
102	252	380	500	632	758	884	1022	1137	1264
104	259	389	513	648	777	906	1047	1165	1295
106	265	398	525	663	796	928	1072	1193	1326
108	271	408	537	679	814	950	1098	1222	1358
110	278	417	550	695	834	972	1124	1250	1389
112	284	427	563	711	853	994	1149	1279	1421
114	290	437	575	727	872	1017	1175	1308	1453
116	297	446	588	743	891	1039	1201	1337	1485
118	303	456	601	759	910	1062	1227	1366	1518
120	310	466	614	775	930	1084	1253	1395	1550
122	316	476	626	792	949	1107	1280	1424	1583
124	323	485	639	808	969	1130	1306	1453	1615
126	329	495	652	824	989	1153	1333	1483	1648
128	336	505	665	841	1008	1176	1359	1513	1681
130	342	515	679	857	1028	1199	1386	1542	1714
132	349	525	692	874	1048	1222	1413	1572	1747
134	356	535	705	891	1068	1246	1440	1602	1781
136	362	545	718	908	1088	1269	1467	1632	1814
138	369	555	731	924	1108	1293	1494	1663	1848
140	376	565	745	941	1129	1316	1521	1693	1881

Δtm (K) = difference between mean water temperature and the room temperature
 K = coefficient related to the heating body
 n = exponent related to the heating body

The thermal emissions are calculated according to the following fomula: $Q = K \cdot (\Delta tm)^n$
 The tests have been carried out by Kermi GmbH laboratory in Plattling, Germany



Pressure drop in Pa for each meter of Duck Strip radiant panel (Mean temperature = 80 °C).

Pressure drop of series DS-ST18 with type "B" Header

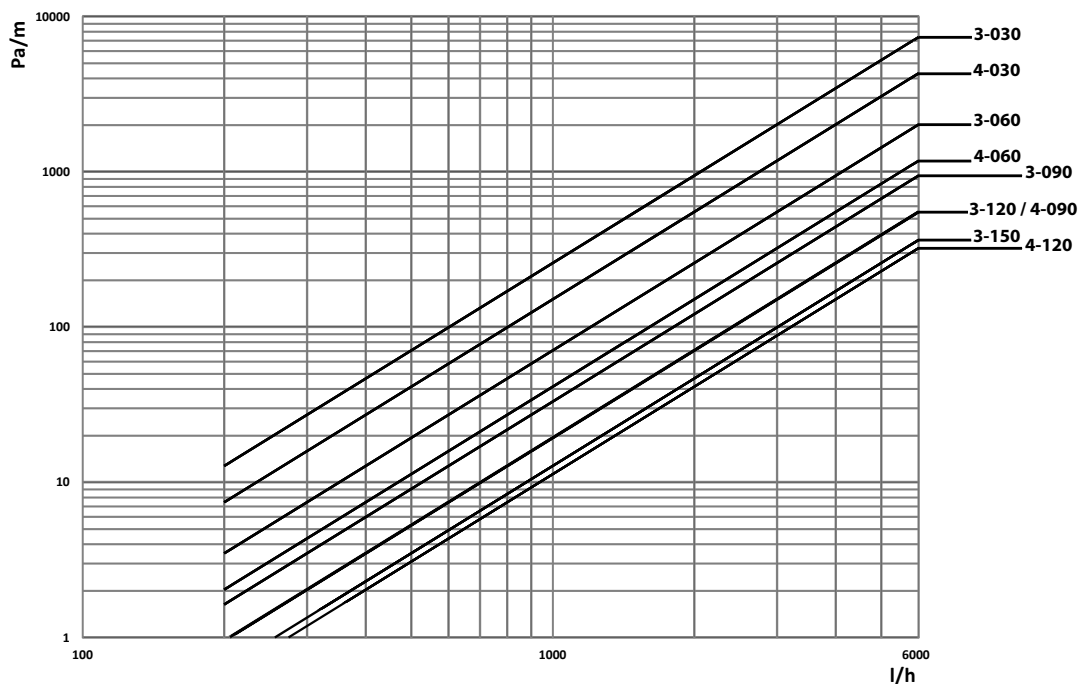

Pressure drop of series DS-ST18 with type "D" Header

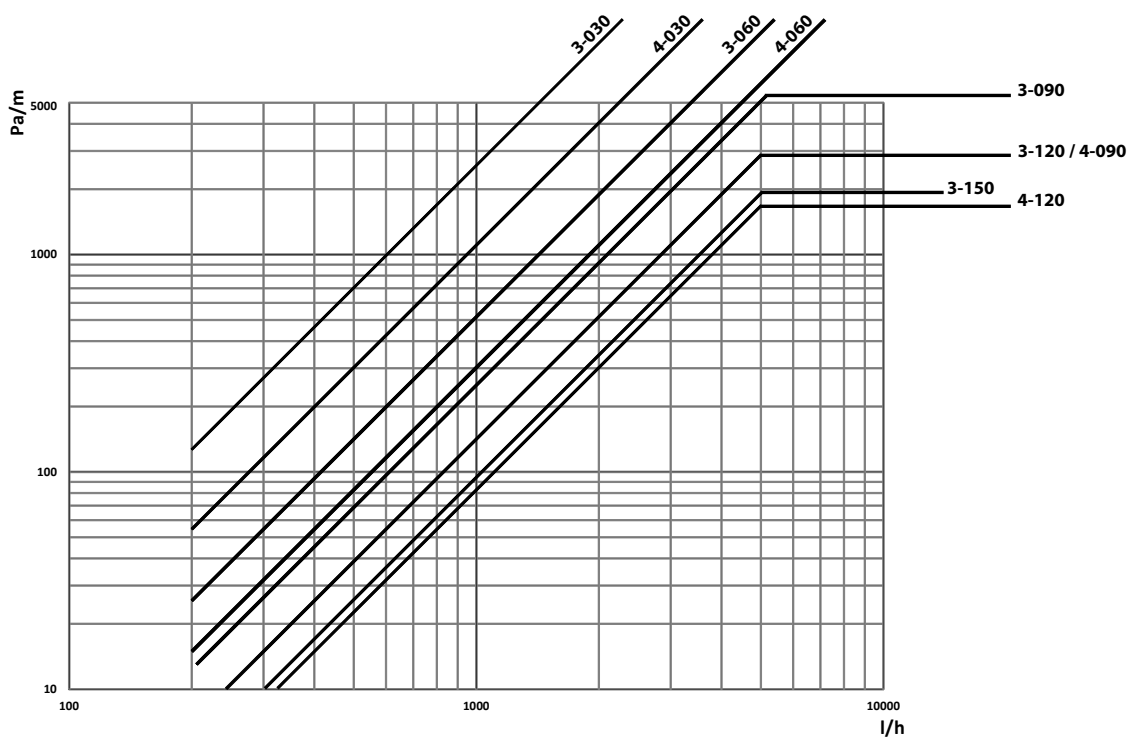

Correction coefficients for average water temperatures other than 80 °C:

TEMPERATURE (°C)	40	60	80	100	120	140
MULTIPLIER (K)	1.24	1.12	1.00	0.94	0.90	0.87

Pressure drop in Pa for each meter of Duck Strip radiant panel (Mean temperature = 80 °C).

Pressure drop of series DS-ST18 with type "G" Header

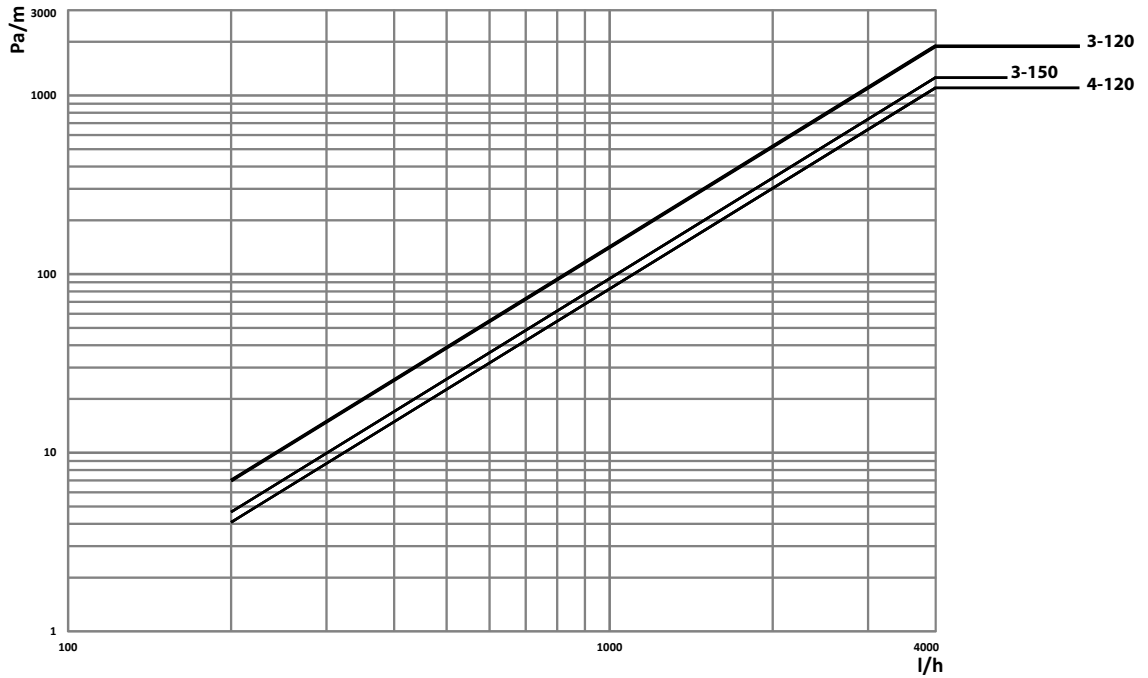

Legend:

Pa/m = Pressure drop

l/h = Water flow rate

Correction coefficients for average water temperatures other than 80 °C:

TEMPERATURE (°C)	40	60	80	100	120	140
MULTIPLIER (K)	1.24	1.12	1.00	0.94	0.90	0.87



Pressure drop in Pa for each meter of Duck Strip radiant panel (Mean temperature = 80 °C).

Pressure drop of series DS-ST28 with type "B" Header

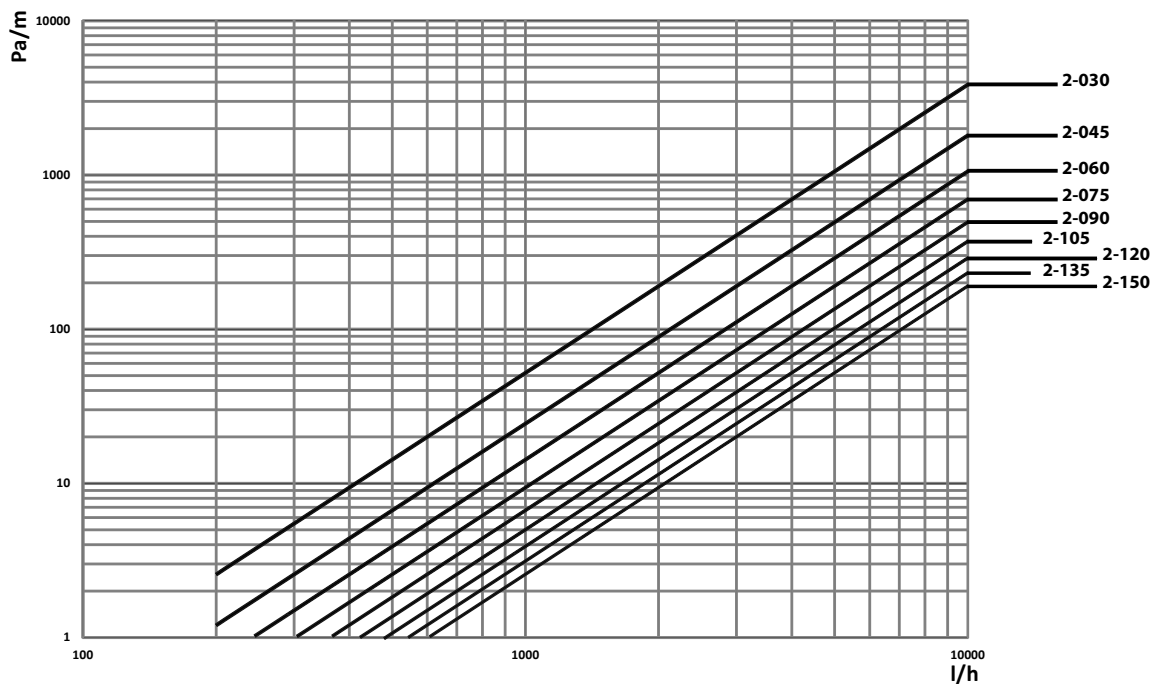

Pressure drop of series DS-ST28 with type "D" Header

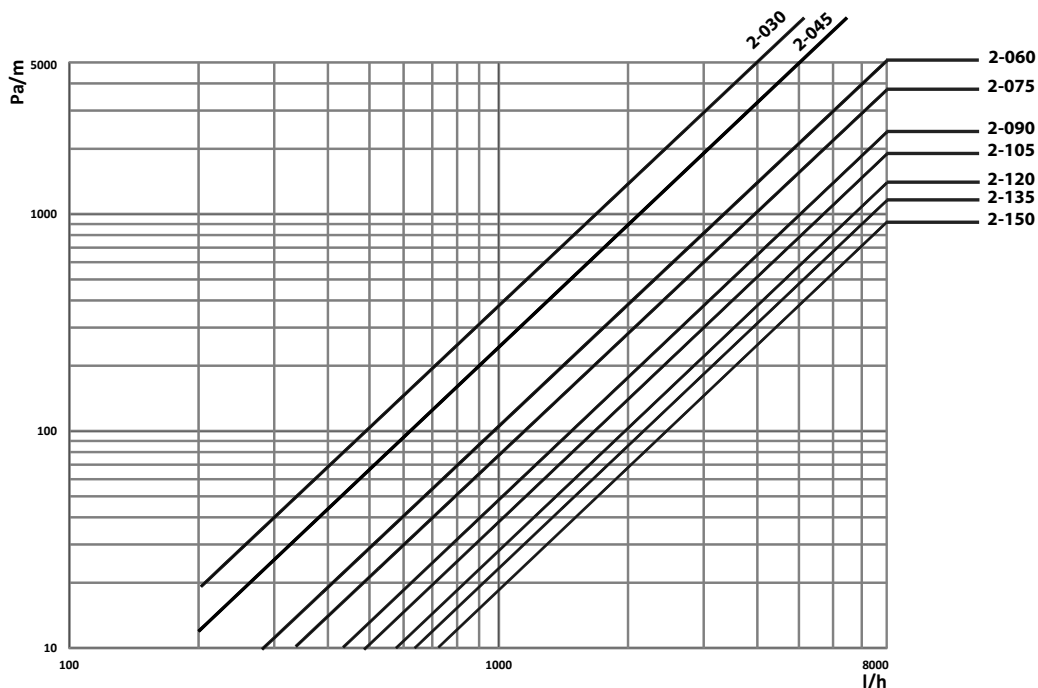

Correction coefficients for average water temperatures other than 80 °C:

TEMPERATURE (°C)	40	60	80	100	120	140
MULTIPLIER (K)	1.24	1.12	1.00	0.94	0.90	0.87

Pressure drop in Pa for each meter of Duck Strip radiant panel (Mean temperature = 80 °C).

Pressure drop of series DS-ST28 with type "G" Header

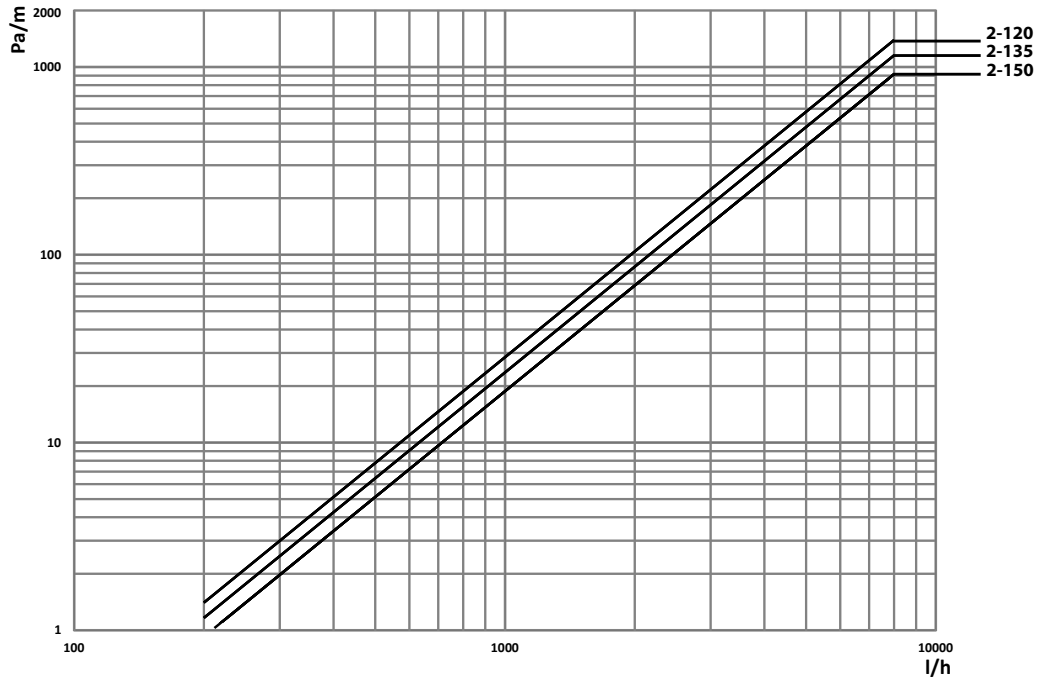

Legend:

Pa/m = Pressure drop

l/h = Water flow rate

Correction coefficients for average water temperatures other than 80 °C:

TEMPERATURE (°C)	40	60	80	100	120	140
MULTIPLIER (K)	1.24	1.12	1.00	0.94	0.90	0.87



Pressure drop in Pa for a couple of headers (Mean temperature = 80 °C).

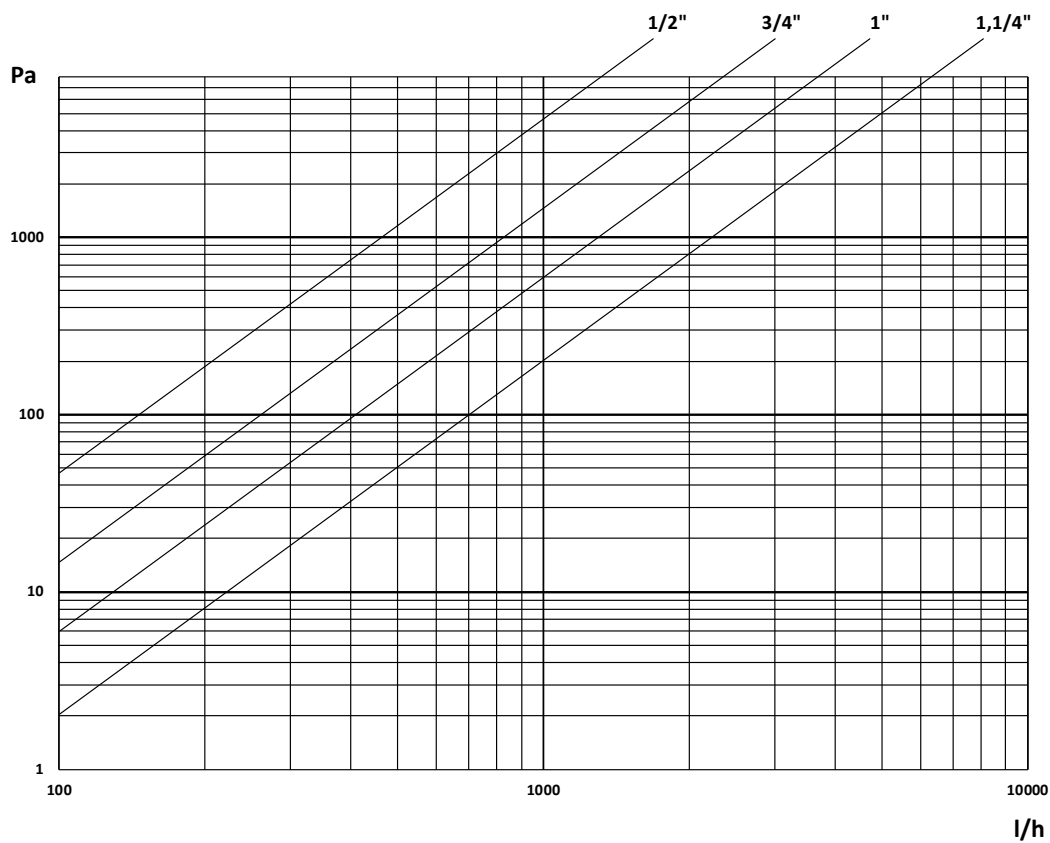

Legend:

Pa/m = Pressure drop

l/h = Water flow rate

Correction coefficients for average water temperatures other than 80 °C:

TEMPERATURE (°C)	40	60	80	100	120	140
MULTIPLIER (K)	1.24	1.12	1.00	0.94	0.90	0.87

Weight and water content

Model		RADIANT PANEL				HEADER		
		Weight kg/m		Water content l/m		Weight kg		Water content
Standard	Special	Standard	Special	Standard	Special	Empty	With water	l
DS-ST18-3-030	-	4	-	0,57	-	1,0	1,64	0,64
DS-ST18-3-060	-	8	-	1,15	-	2,0	3,33	1,33
DS-ST18-3-090	-	12	-	1,72	-	2,9	4,92	2,02
DS-ST18-3-120	-	16	-	2,29	-	3,8	6,51	2,71
DS-ST18-3-150	-	19	-	2,87	-	4,7	8,10	3,40
DS-ST18-4-030	-	5	-	0,77	-	1,0	1,64	0,64
DS-ST18-4-060	-	9	-	1,53	-	2,0	3,33	1,33
DS-ST18-4-090	-	14	-	2,29	-	2,9	4,92	2,02
DS-ST18-4-120	-	18	-	3,06	-	3,8	6,51	2,71
DS-ST28-2-030	DS-SP28-2-030	6	6,6	0,98	0,91	1,0	1,64	0,64
DS-ST28-2-045	DS-SP28-2-045	9	9,9	1,47	1,36	1,5	2,49	0,99
DS-ST28-2-060	DS-SP28-2-060	11	12,2	1,96	1,81	2,0	3,33	1,33
DS-ST28-2-075	DS-SP28-2-075	14	15,5	2,45	2,26	2,4	4,08	1,68
DS-ST28-2-090	DS-SP28-2-090	16	17,8	2,95	2,71	2,9	4,92	2,02
DS-ST28-2-105	DS-SP28-2-105	19	21,1	3,44	3,17	3,3	5,67	2,37
DS-ST28-2-120	DS-SP28-2-120	22	24,4	3,93	3,62	3,8	6,51	2,71
DS-ST28-2-135	DS-SP28-2-135	24	26,7	4,42	4,07	4,3	7,36	3,06
DS-ST28-2-150	DS-SP28-2-150	27	30,0	4,91	4,52	4,7	8,10	3,40

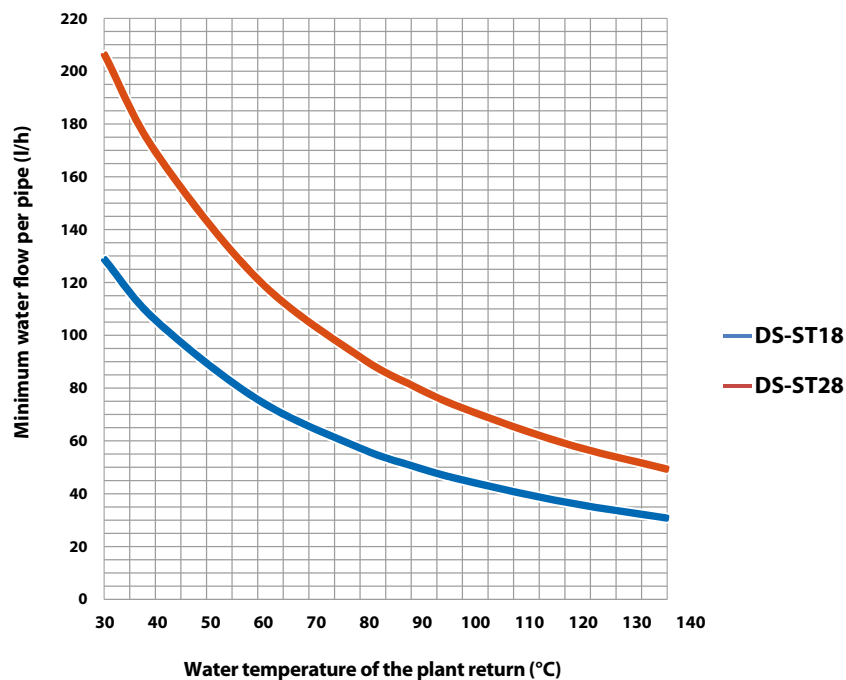
Minimum water flow rates



The assembly height of the Duck Strip radiant panels must be, compatibly with the temperature of the available heating fluid, as low as possible in order to achieve the least dispersion of the radiant effect, due to the proximity of perimeter walls or the presence of dust in the air below the panels. Except from the point of view of the drop in efficiency due to any suspended microparticles that can absorb a minimum part of the radiant heat emission, there are no limitations in terms of installation height.

In fact, if the installation level of a hypothetical complete radiant ceiling is raised, the surface that radiates heat on the person below would increase proportionally to the square of the height above the person, while the intensity of radiation received by the person and emitted by each radiant ceiling surface unit would decrease proportionally to the square of the distance from the person: on the basis of these physical laws, the total radiant heat received by the person remains constant. On the other hand, there are limitations in terms of the minimum installation height of the radiant surfaces, according to the average temperature values of the heating fluid.

The recommended minimum heights, for the 2 models DS-ST18 and DS-ST28 are shown in the table below, applicable for horizontal installations and in relation to people who carry out stationary work.

Minimum recommended assembly height (in m from floor)

		<i>DS-ST18</i>				<i>DS-ST28</i>			
		<i>18-4-030</i>	<i>18-3-090</i>	<i>18-4-090</i>	<i>18-4-120</i>	<i>28-2-045</i>	<i>28-2-090</i>	<i>28-2-120</i>	<i>28-2-150</i>
		<i>18-3-030</i>	<i>18-4-060</i>	<i>18-3-120</i>	<i>18-3-150</i>	<i>28-2-030</i>	<i>28-2-075</i>	<i>28-2-105</i>	<i>28-2-135</i>
			<i>18-3-060</i>				<i>28-2-060</i>		
Average water temp. °C	60°	3.00	3.10	3.20	3.30	3.10	3.20	3.30	3.40
	70°	3.10	3.20	3.30	3.40	3.20	3.30	3.40	3.50
	80°	3.20	3.30	3.40	3.50	3.30	3.50	3.60	3.70
	90°	3.30	3.50	3.70	3.80	3.40	3.70	3.90	4.00
	100°	3.40	3.70	3.90	4.00	3.50	4.00	4.20	4.30
	110°	3.50	4.00	4.30	4.40	3.60	4.20	4.40	4.60
	120°	-	-	-	-	3.70	4.40	4.70	4.90
	130°	-	-	-	-	3.80	4.60	4.90	5.10
140°	-	-	-	-	3.90	4.80	5.20	5.40	

Average surface temperature

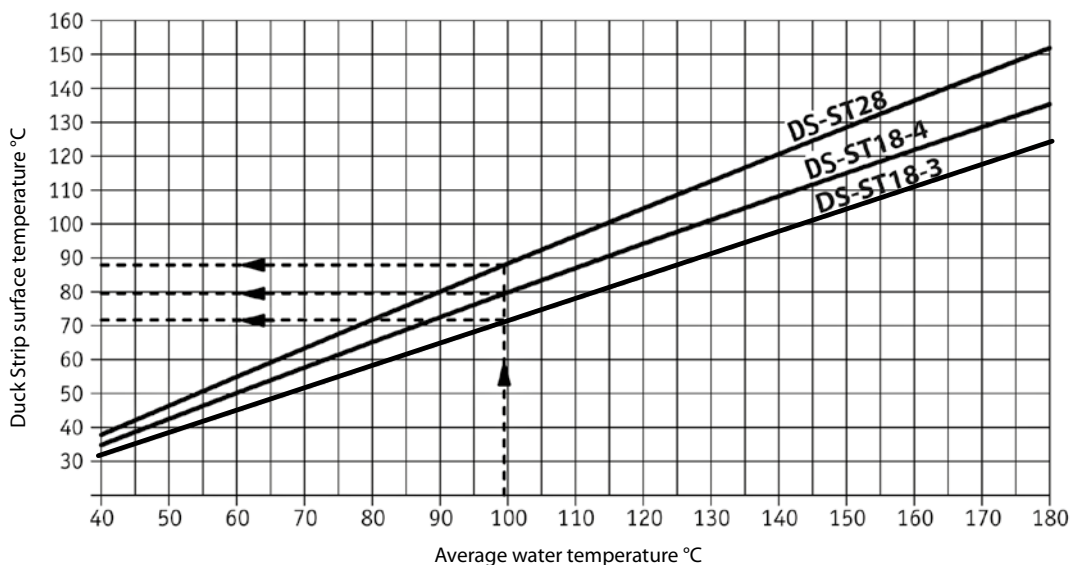

During operation radiant panels behave like all tubes used to convey hot fluids and they are subject to a different expansion depending on the panel length and on the heating fluid temperature.

To avoid excessive stress on the supporting points this expansion should be compensated for. Compensation should be made near the header by using compensators or flexible couplings of a suitable length.

Absolutely avoid the expansion of the supply pipework which could affect the installation of the radiant panel. The table below shows the expansion of a radiant panel in function of its length and of the difference between the panel initial temperature and the design working temperature.

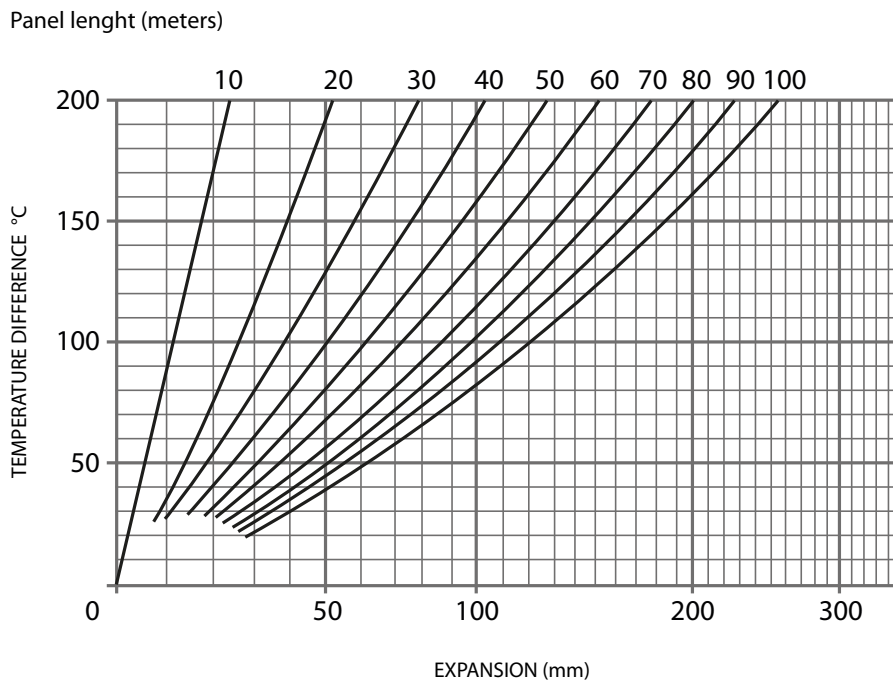

The make-up joint consists of a single piece for sizes 030÷090 and two pieces for sizes 105÷150; the make-up joints are included in the supply.

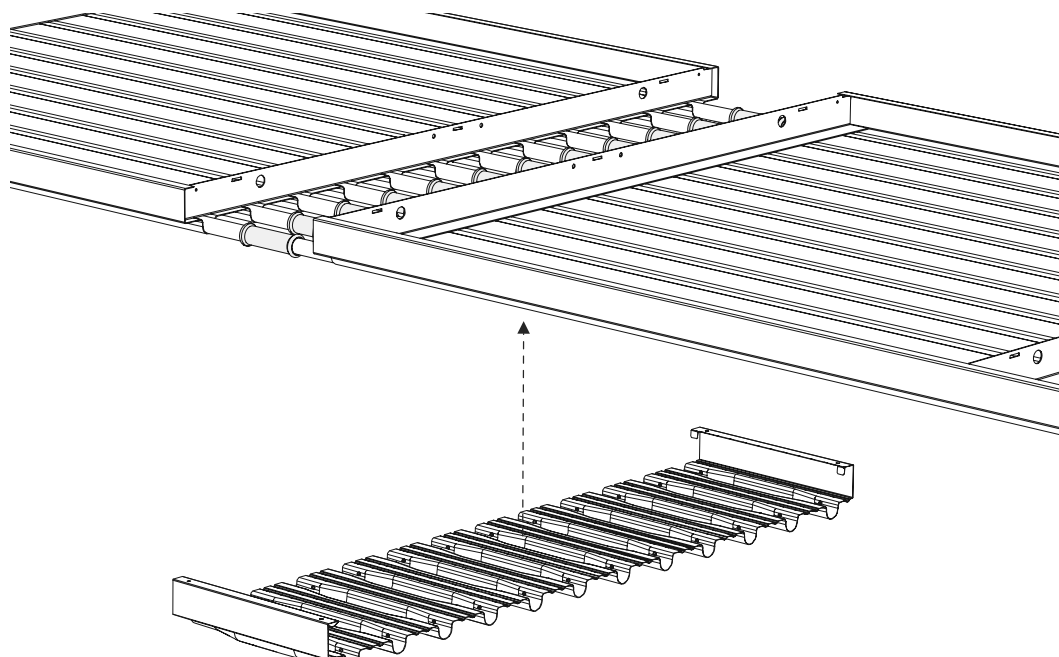

Single piece model (widths from 030 to 090).

Model	L	Ø	No. of pipes	P	Cod.	kg
DS-ST18-3-030	302	18	3	100	9090A221	0.5
DS-ST18-3-060	602	18	6	100	9090A223	0.8
DS-ST18-3-090	902	18	9	100	9090A225	1.2
DS-ST18-4-030	302	18	4	75	9090A241	0.5
DS-ST18-4-060	602	18	8	75	9090A243	0.9
DS-ST18-4-090	902	18	12	75	9090A245	1.3
DS-ST28-2-030	302	28	2	150	9090A231	0.5
DS-ST28-2-045	452	28	3	150	9090A232	0.7
DS-ST28-2-060	602	28	4	150	9090A233	0.9
DS-ST28-2-075	752	28	5	150	9090A234	1
DS-ST28-2-090	902	28	6	150	9090A235	1.2

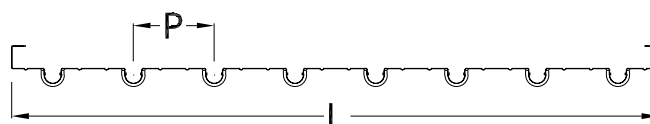

Two pieces model (widths from 105 to 150).

Model	L	Ø	No. of pipes	P	Cod.	kg
DS-ST18-3-120	1202	18	12	100	9090A227	1.6
DS-ST18-3-150	1502	18	15	100	9090A229	2.1
DS-ST18-4-120	1202	18	16	75	9090A247	1.7
DS-ST28-2-105	1052	28	7	150	9090A236	1.4
DS-ST28-2-120	1202	28	8	150	9090A237	1.7
DS-ST28-2-135	1352	28	9	150	9090A238	1.8
DS-ST28-2-150	1502	28	10	150	9090A239	2.1

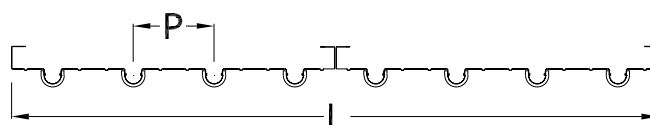

FIBREGLASS INSULATION

Fibreglass insulation (supplied in bulk rolls) with 30 mm standard thickness with 25 micron aluminium sheet support:

- reaction to fire class: A1 according to Standard EN 13501-1;
- thermal conductivity at 20 °C: 0.036 W/mK for 30 mm thickness (0.034 W/mK for 40 mm thickness);
- density: 20 kg/m³ for 30 mm thickness (25 kg/m³ for 40 mm thickness);
- thermal resistance: 0.83 m²K/W for 30 mm thickness (1.17 m²K/W for 40 mm thickness).

On request, 40 mm thick insulation is available (contact the technical department directly).

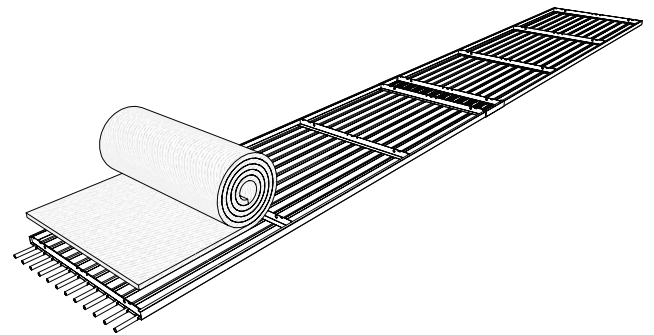

Code	H	L	specific weight kg/m ³	weight kg/m
1050201	30	300	20	0,18
1050202		450		0,27
1050203		600		0,36
1050204		750		0,45
1050205		900		0,54
1050206		1050		0,63
1050207		1200		0,72
1050202+ 1050205		1350		0,81
1050203 + 1050205		1500		0,90
1050211	40	300	25	0,30
1050212		450		0,45
1050213		600		0,60
1050214		750		0,75
1050215		900		0,90
1050216		1050		1,05
1050217		1200		1,20
1050212+ 1050215		1350		1,35
1050213 + 1050215		1500		1,50

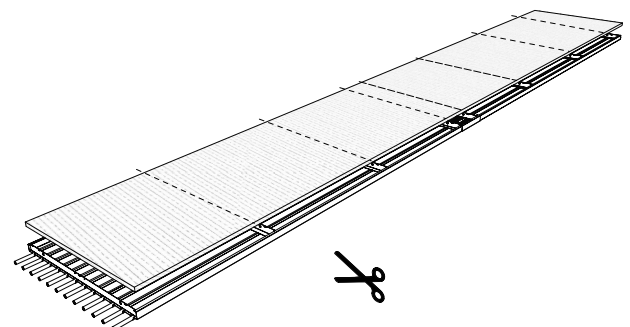
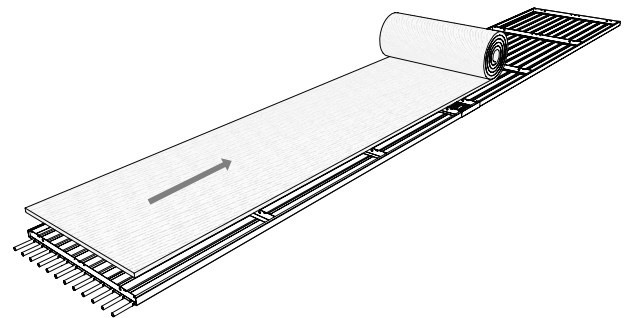

UPPER COVER PANEL FOR GYMS

The "Upper cover panel for gyms" cover consists of two sections:

- an "Upper cover panel kit for gyms". (Consisting of part A length 885 mm + part B length 995 mm)
- a "Upper cover panel joint for gyms". (Part C length 216 mm)

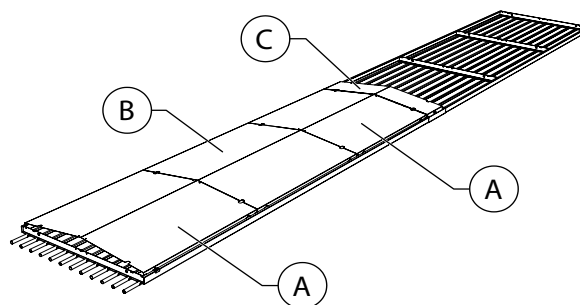

Upper cover panel kit for gyms

The "Upper cover panel kit for gyms" consists of different A and B sections, depending on the length of the panel.

Codes and weights of part A-B

Model		18-030	28-045	18-060	28-075	18-090	28-105	18-120	28-135	18-150
		28-030		28-060		28-090		28-120		28-150
1m	Code	9090A001	9090A002	9090A003	9090A004	9090A005	9090A006	9090A007	9090A008	9090A009
	kg	1,4	2	2,6	3,2	3,9	4,5	5,1	5,8	6,4
2m	Code	9090A011	9090A012	9090A013	9090A014	9090A015	9090A016	9090A017	9090A018	9090A019
	kg	2,8	4	5,2	6,4	7,8	9	10,2	11,6	12,8
3m	Code	9090A021	9090A022	9090A023	9090A024	9090A025	9090A026	9090A027	9090A028	9090A029
	kg	4,3	6,1	7,9	9,7	11,8	13,6	15,4	17,5	19,3
4m	Code	9090A031	9090A032	9090A033	9090A034	9090A035	9090A036	9090A037	9090A038	9090A039
	kg	5,8	8,2	10,6	13	15,8	18,2	20,6	23,4	25,8
5m	Code	9090A041	9090A042	9090A043	9090A044	9090A045	9090A046	9090A047	9090A048	9090A049
	kg	7,3	10,3	13,3	16,3	19,8	22,8	25,8	29,3	32,3
6m	Code	9090A051	9090A052	9090A053	9090A054	9090A055	9090A056	9090A057	9090A058	9090A059
	kg	8,8	12,4	16	19,6	23,8	27,4	31	35,2	38,8

Dimensions of part A-B

Model		18-030	28-045	18-060	28-075	18-090	28-105	18-120	28-135	18-150
		28-030		28-060		28-090		28-120		28-150
L	mm	272	442	572	722	872	1022	1172	1322	1472
H	mm	38	48	58	68	77	87	97	107	117

Upper cover panel joint for gyms

The "Upper cover panel joint for gyms" is used for covering the junction between two panels and to give continuity to the "Upper cover panel kit for gyms" (see part "C" in the drawing).

The quantity to be ordered is related to the number of junctions that are made between the various panels that make up the installation; indicatively, the quantity is given by the number of "upper cover panel kit for gyms" from which you must subtract 1 (number of joint = Number of upper cover panel kit - 1)

Codes and weights of part C

Model		18-030	28-045	18-060	28-075	18-090	28-105	18-120	28-135	18-150
		28-030		28-060		28-090		28-120		28-150
Code		9090A071	9090A072	9090A073	9090A074	9090A075	9090A076	9090A077	9090A078	9090A079
kg		0,3	0,4	0,5	0,6	0,7	0,8	0,9	1	1,3

COVER PANELS

The "Cover panel" consists of two sections:

- a "Cover panel kit". (Consisting of part A + part B)
- a "Joint for cover panel". (Part C)

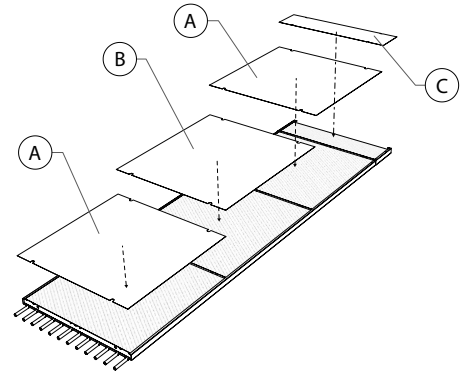

Cover panel kit

The "Cover panel kit" consists of different A and B sections, depending on the length of the panel.

Codes and weights of part A-B

Model		18-030	28-045	18-060	28-075	18-090	28-105	18-120	28-135	18-150
		28-030		28-060		28-090		28-120		
1m	Code	9090A091	9090A092	9090A093	9090A094	9090A095	9090A096	9090A097	9090A098	9090A099
	kg	1.2	1.8	2.4	3.1	3.7	4.3	4.9	5.6	6.2
2m	Code	9090A101	9090A102	9090A103	9090A104	9090A105	9090A106	9090A107	9090A108	9090A109
	kg	2.4	3.6	4.8	6.2	7.4	8.6	9.8	11.2	12.4
3m	Code	9090A111	9090A112	9090A113	9090A114	9090A115	9090A116	9090A117	9090A118	9090A119
	kg	3.8	5.7	7.6	9.7	11.6	13.5	15.4	17.5	19.4
4m	Code	9090A121	9090A122	9090A123	9090A124	9090A125	9090A126	9090A127	9090A128	9090A129
	kg	5.2	7.8	10.4	13.2	15.8	18.4	21	23.8	26.4
5m	Code	9090A131	9090A132	9090A133	9090A134	9090A135	9090A136	9090A137	9090A138	9090A139
	kg	6.6	10	13.2	16.7	20	23.3	26.6	30	33.4
6m	Code	9090A141	9090A142	9090A143	9090A144	9090A145	9090A146	9090A147	9090A148	9090A149
	kg	8	12	16	20	24	28	32	36.4	40.4

Dimensions of part A-B

Model		18-030	28-045	18-060	28-075	18-090	28-105	18-120	28-135	18-150
		28-030		28-060		28-090		28-120		28-150
L	mm	298	448	598	748	898	1048	1198	1348	1498

Joint for cover panel

The "Joint for cover panel " is used for covering the junction between two panels and to give continuity to the "Cover panel kit" (see part "C" in the drawing).

The quantity to be ordered is related to the number of junctions that are made between the various panels that make up the installation; indicatively, the quantity is given by the number of "Cover panel kits" minus 1 (number of joint = Number of Cover panel kits - 1)

Codes and weights of part C

Modello		18-030	28-045	18-060	28-075	18-090	28-105	18-120	28-135	18-150
		28-030		28-060		28-090		28-120		28-150
Code		9090A151	9090A152	9090A153	9090A154	9090A155	9090A156	9090A157	9090A158	9090A159
kg		0,3	0,4	0,6	0,7	0,9	1	1,2	1,3	1,5

MAKE-UP JOINT BETWEEN PANEL AND HEADER

The pipe cover between the panel and the header consists of a single piece for sizes 030÷090 and two pieces for sizes 105÷150.

Buy 2 pieces for each installation.

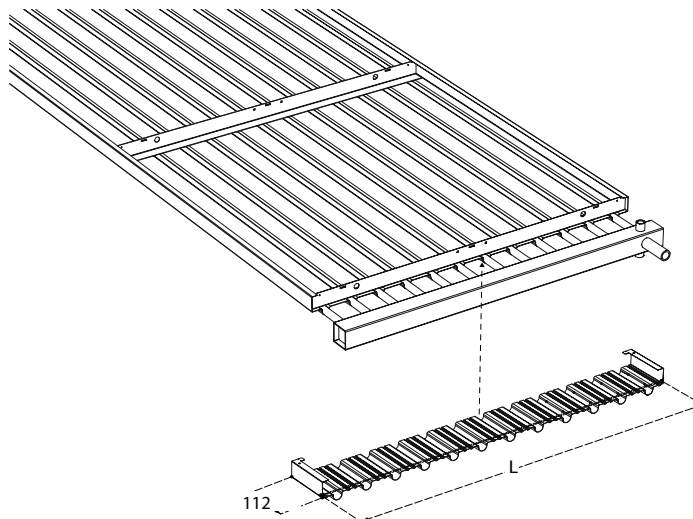

Single piece model (widths from 030 to 090).

Model	L	Ø	No. of pipes	P	Code	kg
DS-ST18-3-030	302	18	3	100	9090A161	0.2
DS-ST18-3-060	602	18	6	100	9090A163	0.5
DS-ST18-3-090	902	18	9	100	9090A165	0.9
DS-ST18-4-030	302	18	4	75	9090A171	0.2
DS-ST18-4-060	602	18	8	75	9090A173	0.5
DS-ST18-4-090	902	18	12	75	9090A175	0.9
DS-ST28-2-030	302	28	2	150	9090A181	0.2
DS-ST28-2-045	452	28	3	150	9090A182	0.4
DS-ST28-2-060	602	28	4	150	9090A183	0.6
DS-ST28-2-075	752	28	5	150	9090A184	0.7
DS-ST28-2-090	902	28	6	150	9090A185	0.9

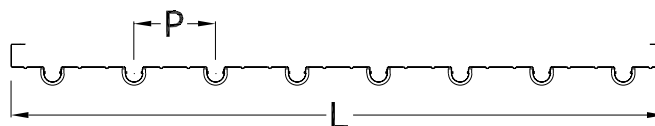

Two piece model (widths from 105 to 150).

Model	L	Ø	No. of pipes	P	Code	kg
DS-ST18-3-120	1202	18	12	100	9090A167	1.3
DS-ST18-3-150	1502	18	15	100	9090A169	1.8
DS-ST18-4-120	1202	18	16	75	9090A177	1.4
DS-ST28-2-105	1052	28	7	150	9090A186	1.1
DS-ST28-2-120	1202	28	8	150	9090A187	1.4
DS-ST28-2-135	1352	28	9	150	9090A188	1.5
DS-ST28-2-150	1502	28	10	150	9090A189	1.7

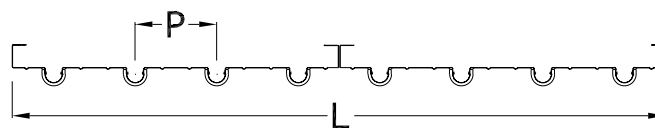

COVER PANEL WITH RAISED HEADER

For all models.

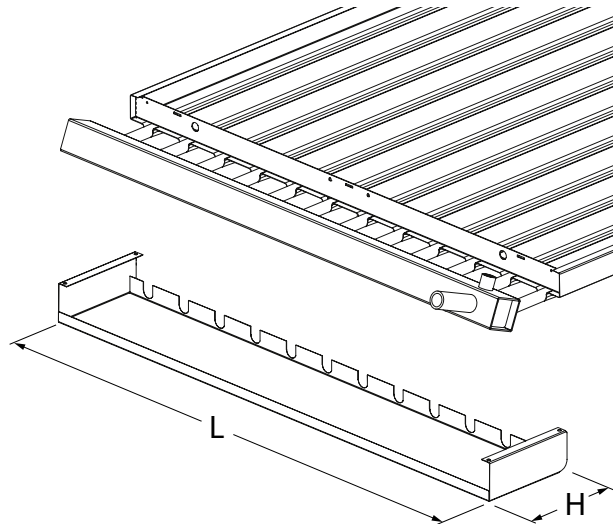

KIT	L	H	kg	Code
DS-ST28-2-030	302	75	0.59	9090A211
DS-ST18-3-030	302	65	0.62	9090A191
DS-ST18-4-030	302	65	0.62	9090A201
DS-ST28-2-045	452	75	0.78	9090A212
DS-ST28-2-060	602	75	0.97	9090A213
DS-ST18-3-060	602	65	0.95	9090A193
DS-ST18-4-060	602	65	0.95	9090A203
DS-ST28-2-075	752	75	1.16	9090A214
DS-ST28-2-090	902	75	1.34	9090A215
DS-ST18-3-090	902	65	1.31	9090A195
DS-ST18-4-090	902	65	1.31	9090A205
DS-ST28-2-105	1052	75	1.53	9090A216
DS-ST28-2-120	1202	75	1.72	9090A217
DS-ST18-3-120	1202	65	1.69	9090A197
DS-ST18-4-120	1202	65	1.69	9090A207
DS-ST28-2-135	1352	75	1.91	9090A218
DS-ST28-2-150	1502	75	2.1	9090A219
DS-ST18-3-150	1502	65	1.9	9090A199

HANGING BRACKET FOR HANGING MULTIPLE PANELS

The hanging brackets are used for hanging multiple panels.

Mod. 030/2

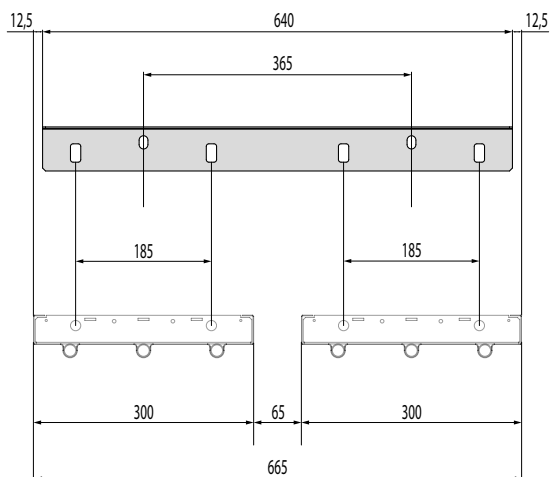

Mod. 030/3

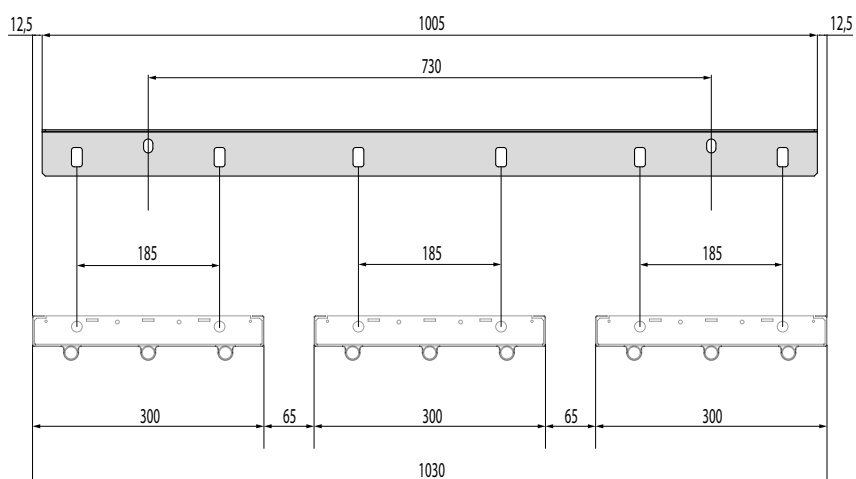

Mod. 030/4

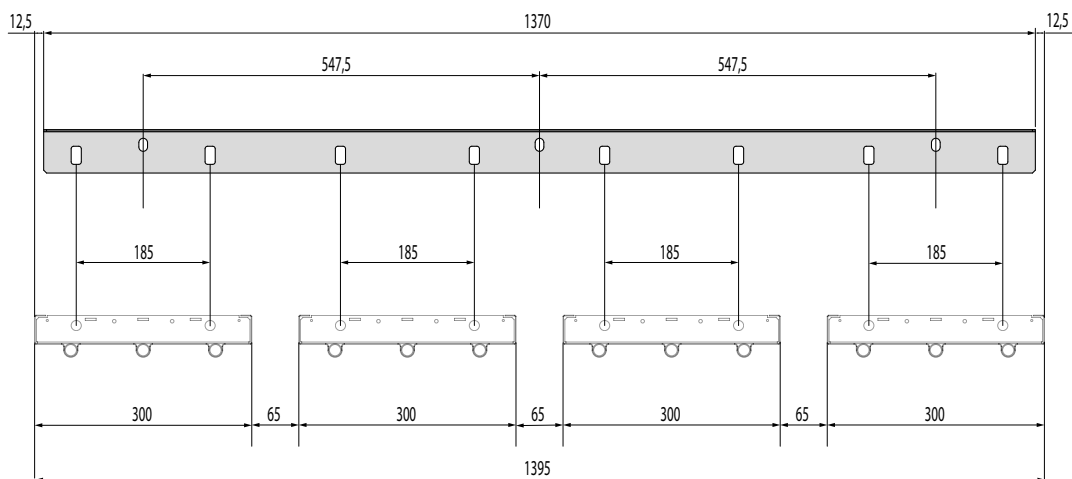

Mod. 060/2

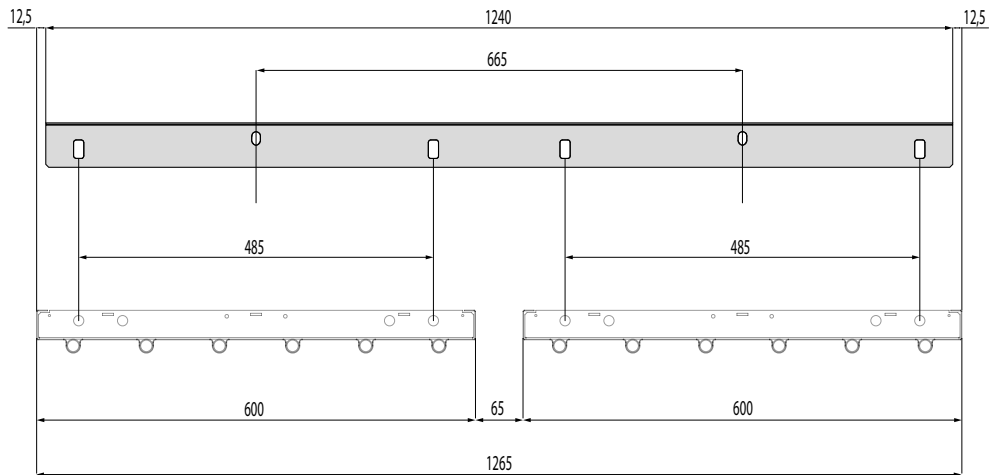

Mod. 090/2

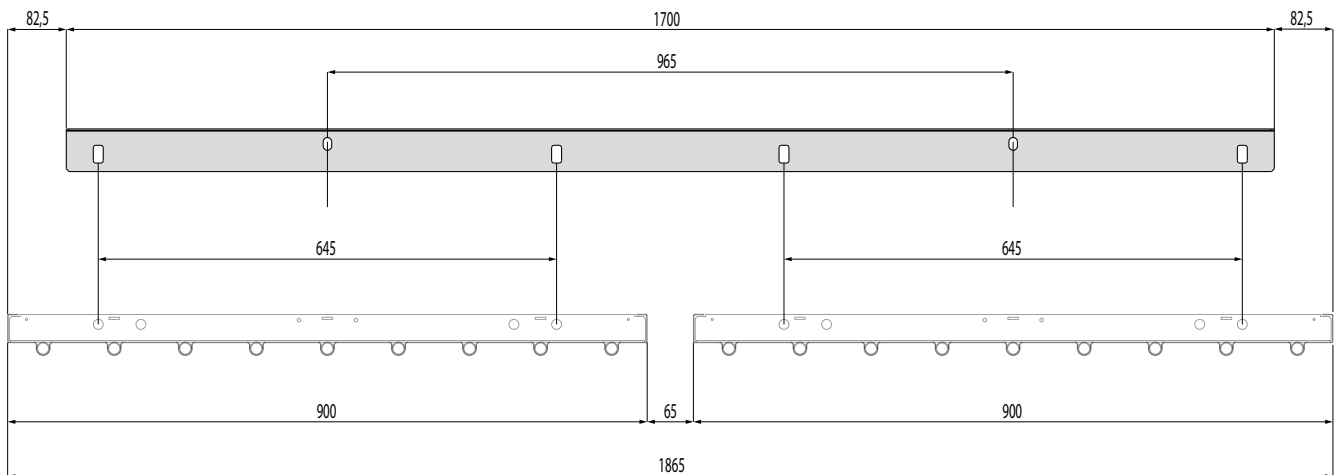

Model	Number of panels	Code
DS-ST18 / DS-ST28		
030	2	6090145
030	3	6090146
030	4	6090147
060	2	6090148
090	2	6090149

ANTI-CONVECTIVE SIDE SKIRTS

Effects of the Duck Skirt anti-convective side skirts

Adding the Duck Skirt anti-convective side skirts to the insulated horizontal radiant panels improves the ratio between radiant heat and total heat. In fact, the side skirt creates an effective obstacle to the convective movements of the air in contact with the radiant surface, creating and maintaining a layer of still, hot air below the panel and thus preventing the surface from coming into contact and being cooled by the convective movements of cooler air.

A typical first case of installation is that of localised radiant heating of work areas not delimited by walls in large areas, where the lower convective heat dissipation promotes the reduction of the used heat output.

A second typical case is the installation of radiant panels inside corridors between shelving.

In this case the radiation inside the corridor is concentrated, limiting the heating of products placed on the shelves.

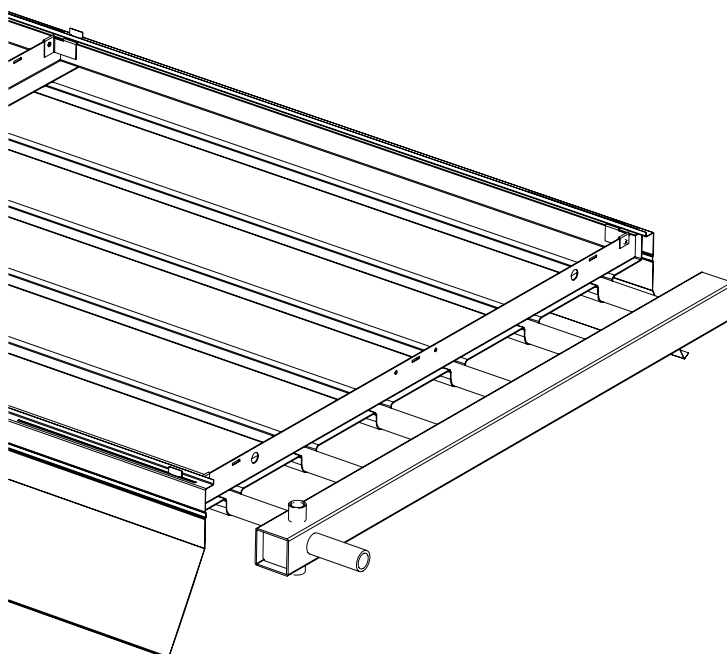

HANGING BRACKET (SLIDING)

The sliding hanging bracket can be used in all cases where, for installation reasons, you require a different hanging point other than those available with the standard DS 4.1.

KIT	L	Code	kg
030	297	9090A081	0.4
045	447	9090A082	0.6
060	597	9090A083	0.8
075	747	9090A084	1
090	897	9090A085	1.2

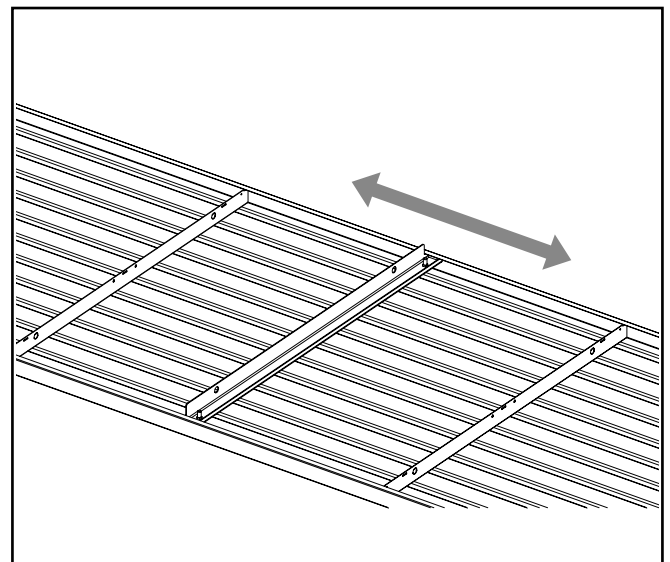
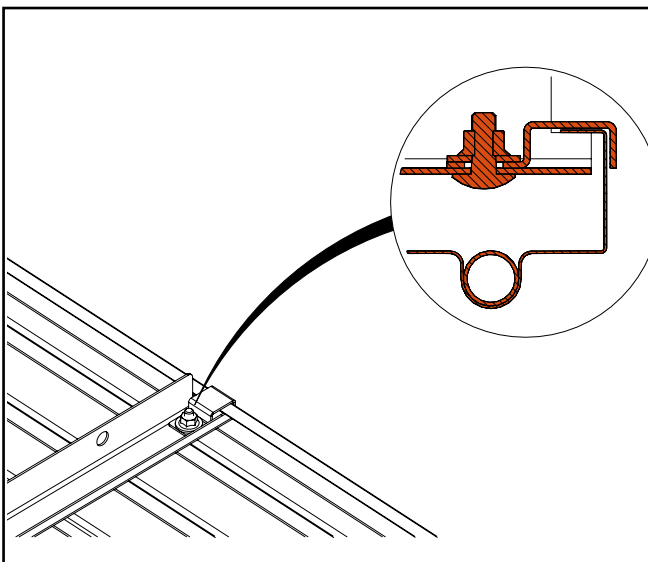
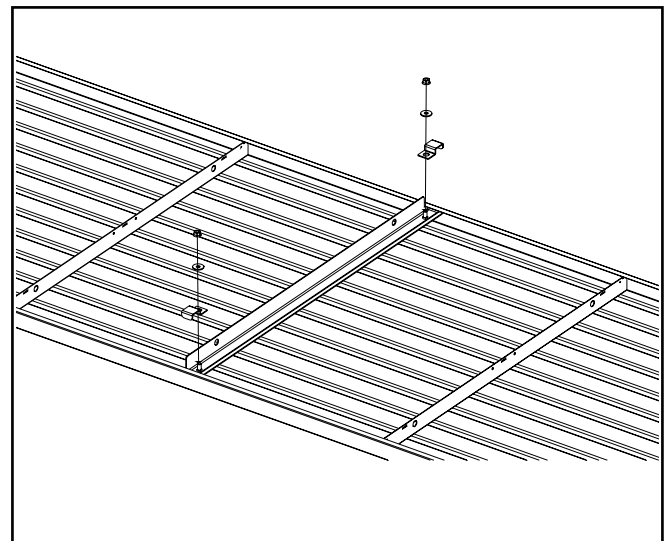
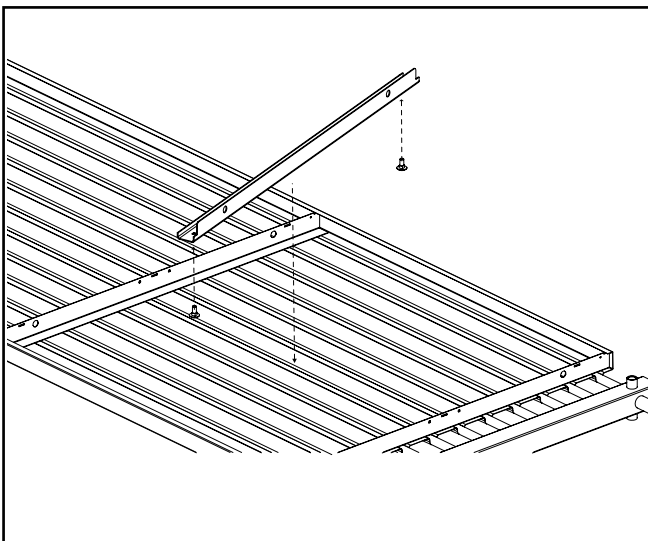
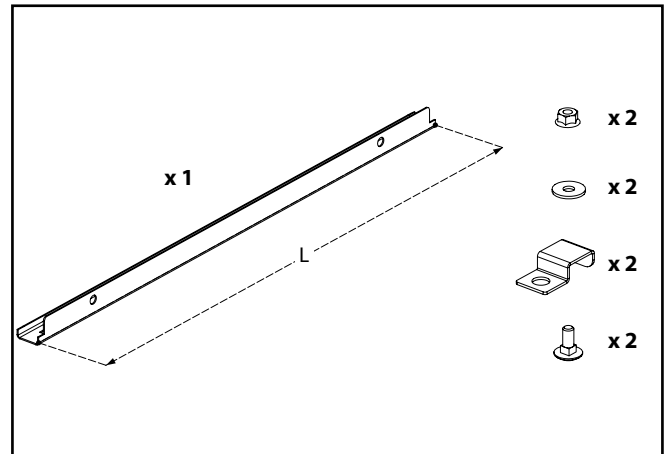

SUSPENSION KIT

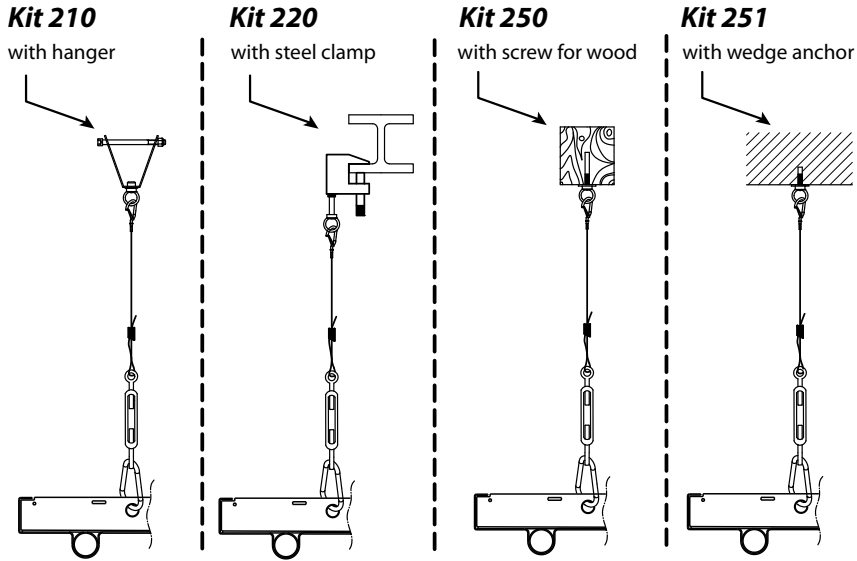

Hanging installations for models 030÷105

For radiant panels with width of 030÷105 they can be installed as follows:

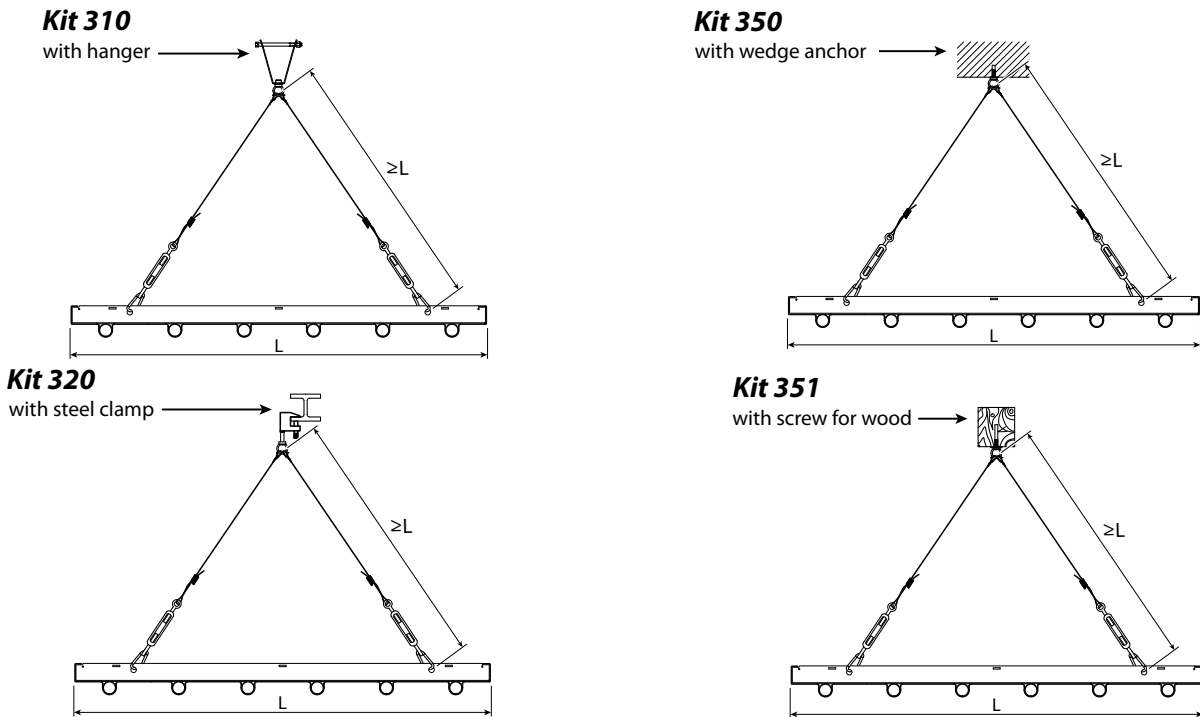

Hanging installations for models 120, 135, 150

For radiant panels with a width of 120, 135 and 150, the suspensions must have the distances indicated in the table below:

Mod.	120	135	150
a	780	855	965
b	1200	1350	1500

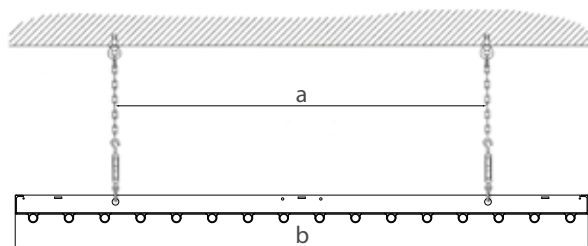

The panels can be joined by pressfittings, allowing quick and precise assembly and consequently savings in labour costs.

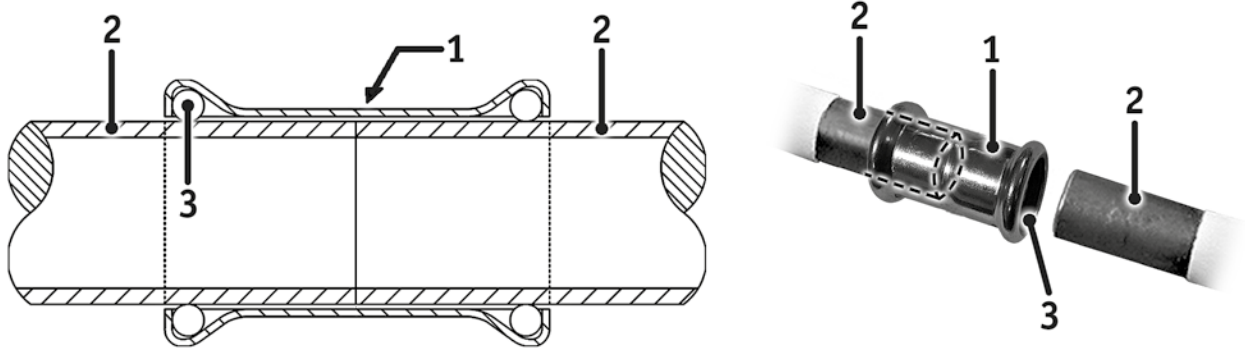

Technical data:

Maximum operating pressure: 10 bar

Maximum operating temperature: 120 °C

1. Linear connection
2. Pipes to be joined
3. O-Ring seals (EPDM)

(indicative data to be verified with the pressfitting supplier)

TEMPERATURE CONTROL

The temperature control must ensure a constant water flow rate in the radiant panels, in order to optimise the efficiency of the system, limit expansion in the radiant panels and reduce the reaction times and oscillation of the temperature control.

It is recommended to use 3-way modulating mixing valves on the flow pipe. Special attention needs to be paid to the choice of the mixing valve serving the radiant panels and/or the speed at which the system water temperature changes. In fact, in order to prevent problems due to the different pipe-sheet metal expansion, in the cold start phase and when changing between the reduced temperature and the comfort temperature, the flow water temperature can easily reach 45 °C without any limitation, beyond which it can rise from 45 °C up to 85 °C, with an increase of 10 °C every 3 minutes for radiant panels equipped with "B" header, and an increase of 10 °C every 4 minutes for radiant panels with "D" header.

To ensure the design water flow in each radiant panel and balance the system, a compensated return can be used (three pipes, Tickelmann system) if the radiant panels are all of the same model, whereas if zone heating or different models of radiant panels are required, automatic flow rate stabilisers should be used on the return of each radiant panel, or regulating valves.

EXTERNAL PROBE WITH FLOW TEMPERATURE CONTROL

Legend

- CP** = Main control unit
- CZ** = Zone control unit
- M** = Motor with 3-way valve
- SD** = Flow probe
- SE** = External probe
- SR** = Room probe
- A** = Supply
- R** = Return

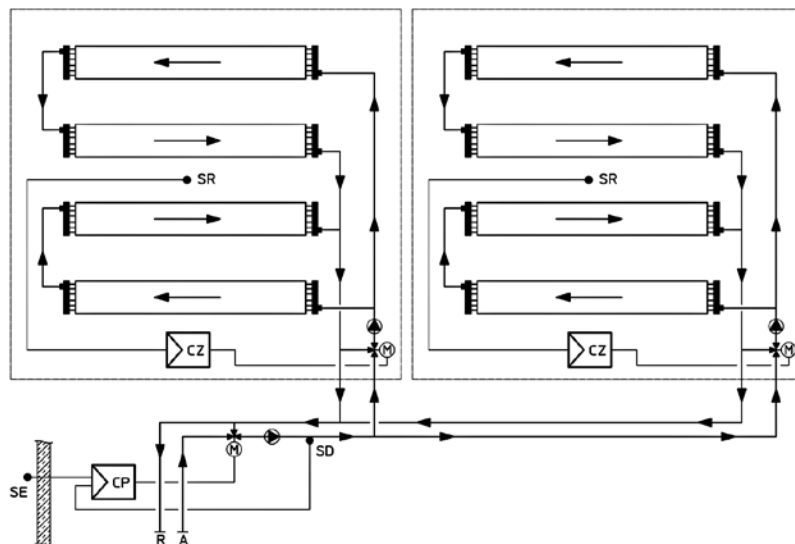
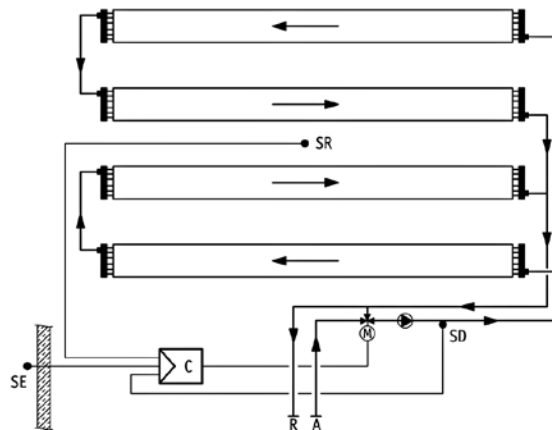

HEADERS AND SUPPLY

"B" HEADER
COMPENSATED LINES

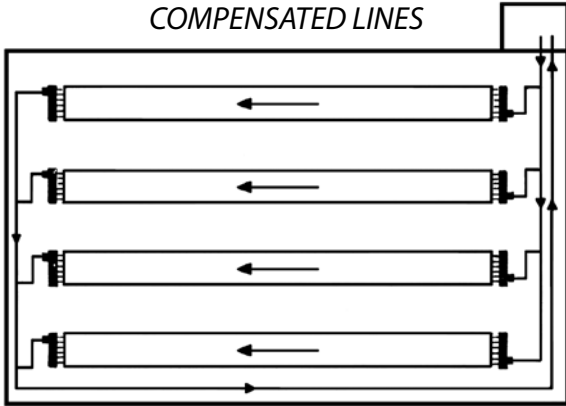

"B" HEADER
COUPLED LINES

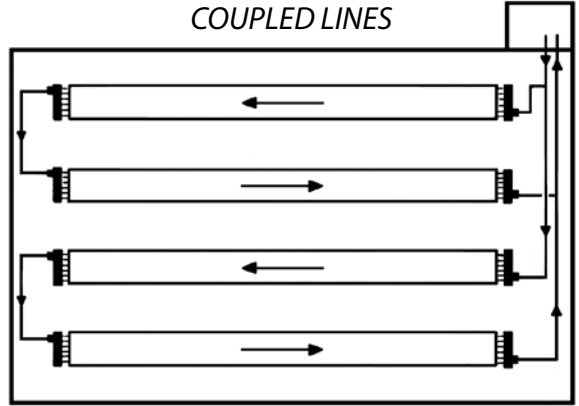

"B" HEADER
LINES IN SERIES

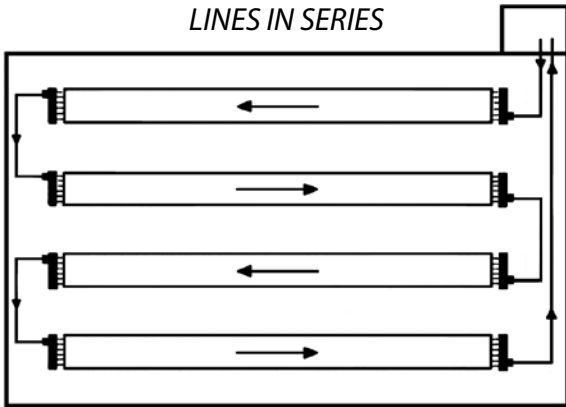

"D" HEADER
COMPENSATED LINES

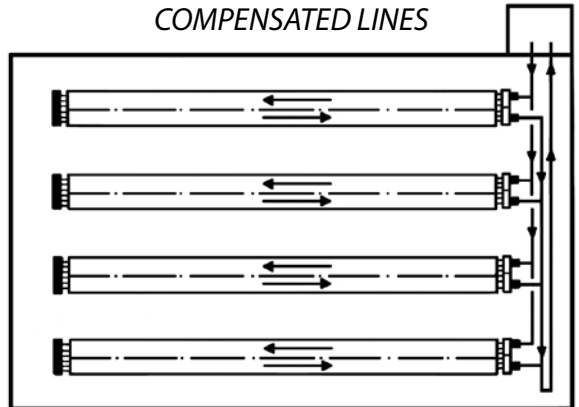

"D" HEADER
LINES IN SERIES

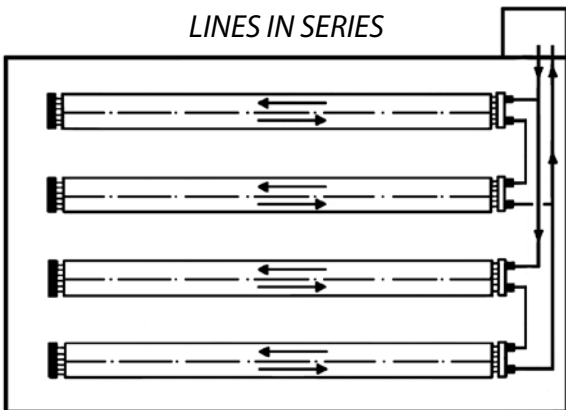

"D+D" HEADER

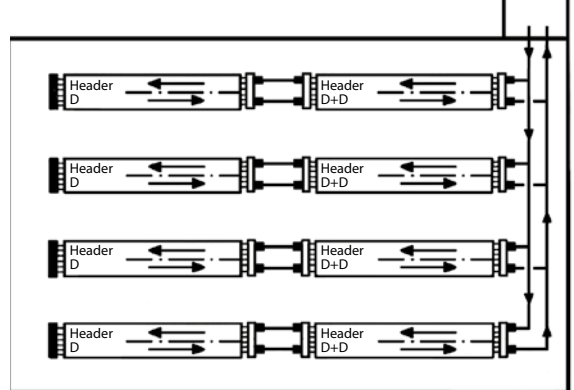

"G" HEADER

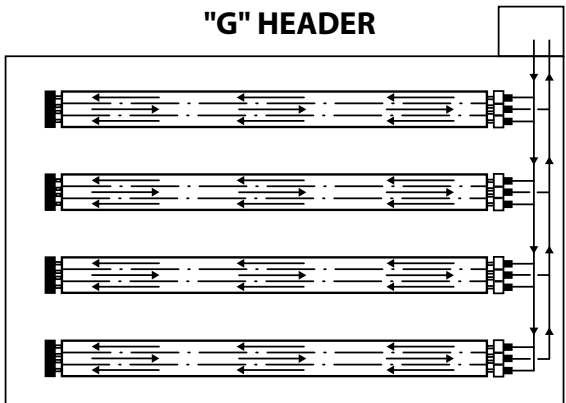

Correct spacing between radiant panels

It has been experimentally and practically found that the good uniformity of heat irradiation over a central area of a building (where the cooling effect of the outer walls can be considered null) is obtained when the centre-to-centre distance between two adjacent Duck Strips is equal to or less than the height from the floor.

For example, where the installation height of the radiant panels is 4 m above the floor, the centre-to-centre distance of the adjacent Duck Strip radiant panels must be set at 4 m or less, in order to achieve the best heating uniformity.

CORRECT INSTALLATION OF DUCK STRIP RADIANT PANELS

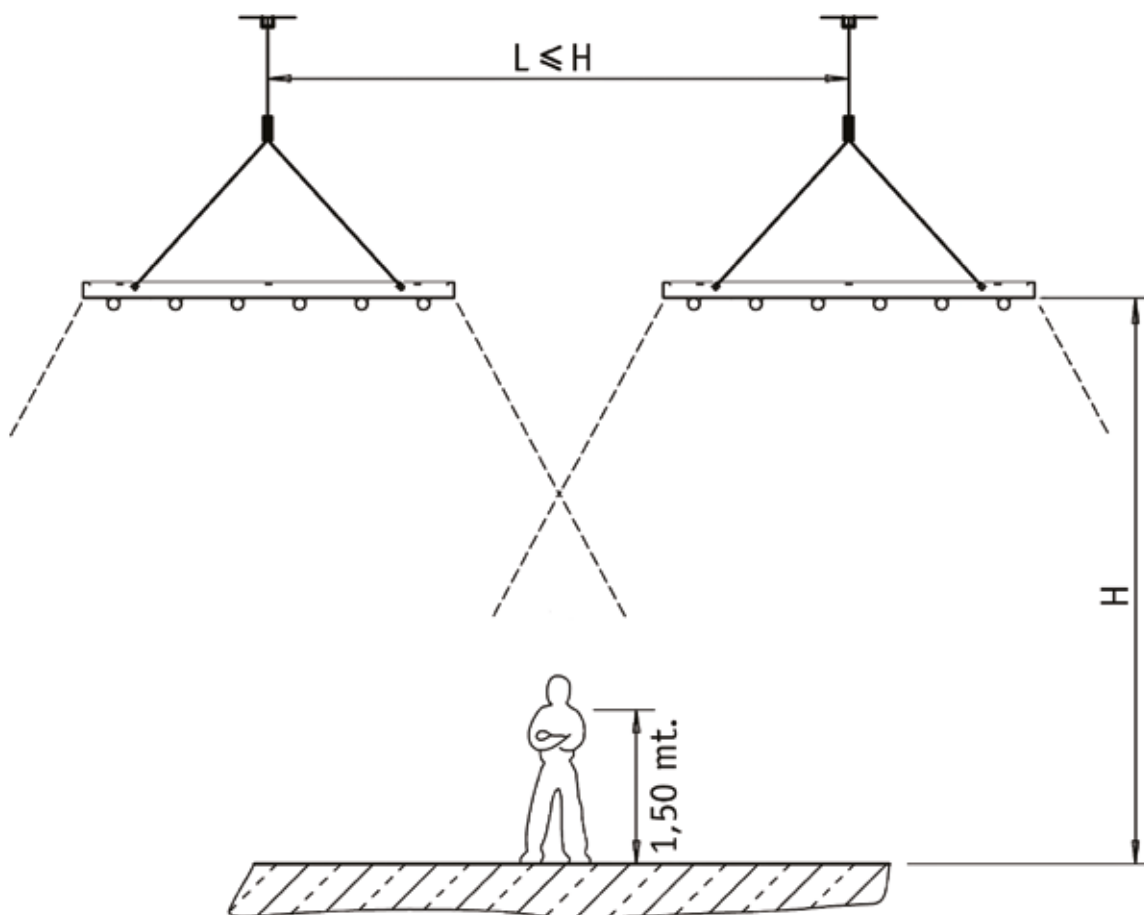

Order example:

2 strip model DS-ST18-3-090 – standard – Im 24 – Man. B – 5/6 – diam. 1" – insulation 30 mm – Ral 9016

The order relating to Duck Strip 4.1 radiant panels must contain the following information (to be repeated for each model and length):

1. **No. of strips:** indicate the number of lines having the same model and the same length
2. **Radiant panel model:** DS-ST18-3-090
3. **Nominal width:** 090 (900 mm)
4. **Model of the pipes:** "standard" execution with electrowelded pipes or "special" execution (only for model DS-SP28-2) with pipes without welding, specifying the operating pressure if higher than 4 bar
5. **Nominal length of the strip:** for the actual lengths up to 50 m please refer to the appropriate table
6. **Model of header:** indicate the type of desired headers "B", "D", "D+D" or "G"
7. **Position of the connection :** specify the reference numbers for the inlet and outlet connections listed in the tables.
8. **Diameters of the connections:** male threaded \varnothing 1/2" – 3/4" – 1" – 1.1/4"
9. **Insulation:** standard insulation padding, 30 mm thickness, density 20 kg/m³. Other executions only on request
10. **Colour:** indicate the required colour: Ral 9016 white - Ral 9002 light grey. Other Ral colours on request with additional charges.



A company of Arbonia Group
ARBONIA ▲

Follow us on



Sabiana app



SABIANA SpA

Società a socio unico

Via Piave 53 - 20011 Corbetta (MI) Italy

T. +39 02 97203 1 r.a. • F. +39 02 9777282

info@sabiana.it

www.sabiana.it